

The Loveship: UNLV's First High-Powered Rocket

Team 64 Project Technical Report for the 2019 IREC

Brandon Fallon, Mariana Rodriguez, Edgar Salas-Sanchez, Jacob Reed, Cody McDonald, Brandon Avendano
University of Nevada- Las Vegas, Las Vegas, NV, 89154

The Students for the Exploration and Development of Space (SEDS) chapter at the University of Nevada, Las Vegas is a new student organization looking to grow and develop by participating in the 2019 Intercollegiate Rocket Engineering Competition. The team's entry into the competition is the rocket *The Loveship*, a 6.15 ft tall, 6.17 in diameter rocket launching on a COTS L1115 motor. The team is entered into the 10,000 ft COTS motor category. The mission objective is to launch *The Loveship* and recover the rocket, as well as to recover its payload once deployed. For the first year, team members spent time learning the layup process required to construct composite fins, developing an ejectable payload with an inflatable habitat module, and discovering how telemetry and data logging systems worked. Using knowledge gained from this year's experiences, SEDS UNLV hopes to be able to make better, more efficient rockets for the future.

Nomenclature

Cp	=	Center of pressure
Cg	=	Center of gravity
Cd	=	Coefficient of drag
AGL	=	above ground level
RRC3	=	Rocket Recovery Controller 3
RTx	=	Radio Transmitter
GPS	=	Global Positioning System
NMEA	=	National Marine Electronics Association
LCD	=	Liquid-Crystal Display
RFT	=	Radio frequency transmitter

I. Introduction

THE Students for the Exploration and Development of Space (SEDS) chapter at the University of Nevada, Las Vegas (UNLV) is an engineering student organization aiming to grow students' technical and leadership skills as well as enable students to pursue careers in the aerospace industry in the absence of an aerospace engineering department at UNLV. The organization was established in the past year to foster a growing interest in aerospace engineering at UNLV, providing an environment in which students can become familiar with high-powered rocketry. The first year of rocketry activity included obtaining Level 1 and 2 rocketry certifications as well as designing, building, and preparing for the 2019 Intercollegiate Rocket Engineering Competition (IREC).

This year, IREC will mark the chapter's first entry and participation in a collegiate rocketry competition. The team will be representing UNLV with the rocket *The Loveship* in the 10,000 ft. commercial-off-the-shelf (COTS) propulsion category. The launch vehicle mission objective is to launch *The Loveship* to an apogee of 10,000 feet, successfully deploy recovery mechanisms, and subsequently recover the rocket in a reusable state. The payload mission objective is to deploy the payload unit, deploy its recovery mechanisms, activate the payload upon landing, and subsequently recover the payload. The stakeholders in the SEDS UNLV team's entry into the 2019 IREC are first and foremost the team members, whose hard work and dedication made *The Loveship* a reality in the first place.

The SEDS UNLV rocketry team is an interdisciplinary team of 16 undergraduate students in the disciplines of mechanical engineering, electrical engineering, civil engineering, and computer science. A project lead was selected for the team, and members formed four subgroups to work on the propulsion, airframe, recovery, and payload subsystems. Leads for each of the subsystems were chosen based on experience and interest. The project lead was responsible for meeting scheduling, general documentation, and managing funding for the competition. Subsystem leads were responsible for directing the progress of the subsystem, as well as communicating with the project lead to ensure proper integration among the subsystems and agreement with the rules and requirements. Primary management strategies included thorough documentation of the team's progress made available to all team members as well as constant and efficient communication via group messaging and email to all members. Regular attendance and involvement were expected of members. Google Drive was used as the primary means of file storage for the team, allowing for the sharing of files and notes among members.

II. System Architecture Overview

The Loveship utilizes a commercial off-the-shelf motor and is set to fly approximately 9,500 feet AGL carrying a 3U cubesat payload. The rocket is 73.8750 in long with a 6.17 in outer diameter. The rocket weighs approximately 29 lbs dry (without the motor) and 38.5 lbs wet. A fiberglass nose cone and fiberglass body tubes were employed for strength and for ease of radio communications. The nose cone sports an Ogive shape, which proved better in simulations for subsonic speeds. It is connected to the main body using bulkheads. One bulkhead will be located in the nose cone which will weave its way to the upper body bulkhead. The SRAD fins were 3D printed with ABS plastic and then enforced using a 2-ply carbon fiber layup. Lastly, the SRAD boattail was created using ABS print. An aluminum tube is placed in between boattail and motor to prevent the boattail from being crushed. It is connected to a SRAD thrust plate.



Figure 1: External View of Rocket Body

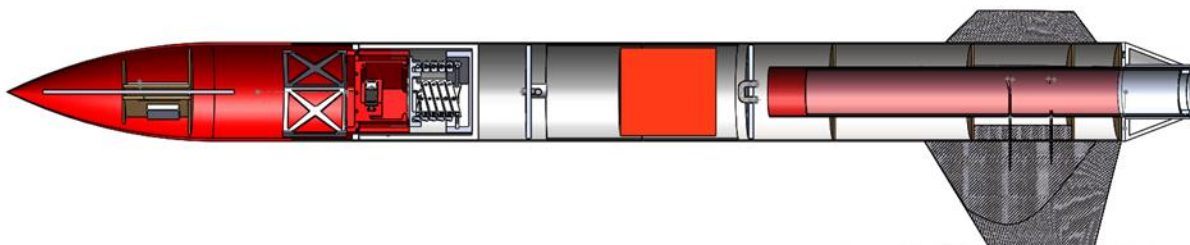

Figure 2: Internal View of Rocket Body

The avionics system is in the nose cone. It is held in position by a rod epoxied to the tip of the nose cone. Furthermore, a bulkhead beneath it will prevent it from slipping out, acting as a failsafe. The payload is located between the nose cone and upper body tube. The upper and middle cube will deploy at 1000 ft using a spring system in the third cube. Finally, a 12 in fiberglass coupler is employed to connect the upper and lower body tube. The tubes are connected via two fiberglass bulkheads located in each frame.

A. Propulsion Subsystems

1. Specifications

After many simulations, the L1115 solid rocket motor made by Cesaroni Technology was chosen. The L1115 is a reloadable 4 grain, 24.45in length by 75 mm diameter motor. It has a total impulse of 4908.732 Ns with an average thrust of 1093.259 N and a burn time of 4.49 seconds. The rocket is set to reach approximately 9,500 ft weighing 38.5 lbs. This was simulated in RockSim. Simulation curves for altitude, velocity, and acceleration are shown below.

2. Simulations

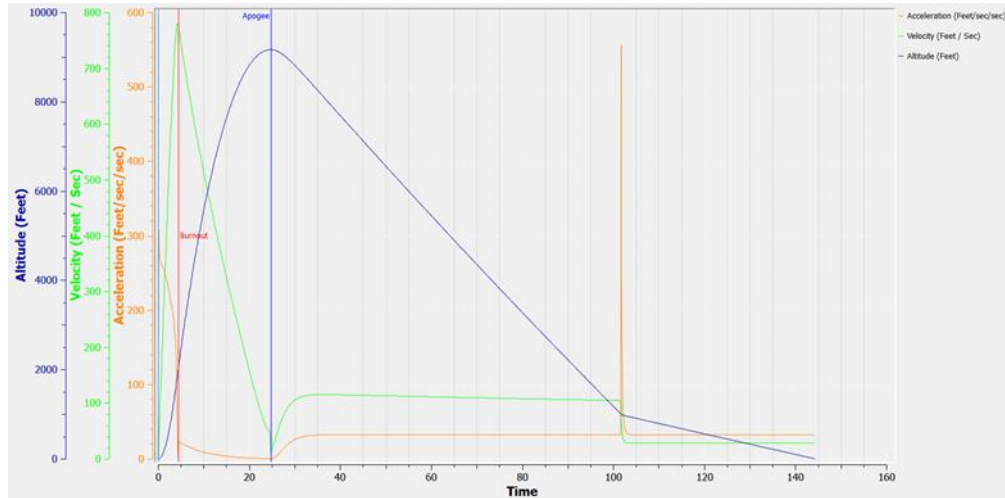

Figure 3 RockSim Flight Trajectory Analysis:

Table 1: Projected Simulation Data

Simulation	Engine	Max Altitude (ft)	Max Velocity (ft/s)	Max acceleration (ft/s ²)	Time to Apogee (s)
102	L-1115	9019.72	778.96	599.61	24.51
103	L-1115	9154.63	779.5	599.61	24.7
104	L-1115	9162.83	779.54	599.61	24.71
105	L-1115	9027.36	779	599.61	24.52













The max velocity found was on average 779 ft/s which equates to a Mach value of 0.69. Having a lower Mach number makes designing the structure significantly easier as there is less of a load on the rocket. Additionally, all values were tested for wind conditions of 8-14 mph. Based on experience, typically rocket launches have been in windy conditions.

As the design and construction of the rocket progressed, there was one major part which had been improperly accounted for, causing a significant drop in the original altitude. This stemmed from the motor casing. From initial estimates, it was thought that the casing only weighed approximately 1.7 lbs, however, when it was finally purchased the true weight was found to be 3.2 lbs. Furthermore, the additional weight of the mount was not properly added, so 2.5 lbs had not been accounted for. When the error was realized, the altitudes listed in the above chart were found. Currently, much experimentation and testing is ongoing in attempt to fix the large altitude discrepancy. Considering this is the team's first time constructing a rocket of this caliber, it was a good lesson learned for the future.

3. Motor Selection Testing

The L-1115 was chosen based off much preliminary testing. Several team members came together to begin testing different designs and motors. Table 2 highlights some early testing which led to the chosen motor.

Table 2: Motor Selection Testing

Simulation	Results	Engines loaded	Max. altitude Feet	Max. velocity Feet / Sec	Max. acceleratic Feet/sec/sec	Time to apogee
0		[L1111ST-*]	10054.46	1194.49	534.23	22.66
1		[L1482-SM-*]	10387.43	1352.91	606.97	22.52
2		[L330-*]	9799.41	874.84	143.88	24.92
3		[L600-*]	14170.34	1154.60	272.79	27.78
4		[L850W-*]	7506.27	729.36	252.23	21.92
5		[L1115-Classic-*]	10770.08	941.52	347.73	25.55
6		[L1115-Classic-*]	10947.47	946.40	348.30	25.80
7		[L1115-Classic-*]	10894.85	945.77	348.30	25.73
8		[L1115-Classic-*]	10745.80	931.23	342.72	25.64
9		[L1482-SM-*]	8133.07	838.74	391.60	22.20
10		[L600-*]	10583.66	788.91	152.39	27.38
11		[L1115-Classic-*]	10777.10	931.31	342.72	25.68

In the preliminary testing, many of the values were based off ideal conditions i.e. minimal wind, polished surfaces, and estimated masses. As time progressed, many of these items would change resulting in our current status. The biggest constraint was being limited to a level 2 motor. This is primarily due to the cost of level 3 motors and the recent establishment of our organization. Giving the shallow time constraints and lack of experience, it was determined that a level 2 motor would be most optimal for time, money, and experience. Furthermore, it pushed the team to design a more efficient rocket with less power.

B. Aero-structures Subsystems

A subgroup was delegated with the task of bringing the simulations to reality. Prior to this competition, nobody on the team had worked with composites material before. Because of this, it was decided that team would be better appropriated if time was spent learning how to one of the 3 primary structures: fins, nose cone, and body tubes. Because it was known that nose cones and body tubes could be purchased, several students on the airframe team decided to develop a method for making composite fins.

To ensure the feasibility of design, SolidWorks simulation was employed in several scenarios. Using SolidWorks flow simulation, computation fluid dynamics was used to evaluate the flow around the rocket. In SolidWorks simulation, finite element analysis was also used to determine whether certain parts of concern would break. SolidWorks was chosen over ANSYS due to the lack of familiarity and experience with ANSYS. Lastly, due to the irregularity of the fins, an external fin stress evaluator, FinSim, was used to as a backup measure to determine if our fins would break.

1. Nose Cone and Body Tubes

Due to lack of time, the nose cone and body tubes were purchased. Based on the common use of fiberglass for high power rockets, a fiberglass frame and nose cone were chosen and bought from Madcow Rocketry. Based on the RockSim simulations, the ideal nose cone was an 18 in Ogive design. The nose cone needs to eject to release the payload. To do this, a bulkhead is placed inside and secured with bolts. A shock cord will connect to this and feed back to another bulkhead inside the tube.

The body is split into two sections, an upper and lower frame. The upper frame is set at 22 in and the lower at 30in. They are connected with a 12 in fiberglass coupler with fiberglass bulkheads on each side. A shock cord is attached to U-bolts on each bulkhead to prevent the loss of the rocket. Figure 4 shows a team member with nose cone and body tube straight out of the container.



Figure 4: New Nose Cone and Body Tube

Due to the limited availability of tools rated for composite materials in our machine shop, student-designed and built jigs were used to cut and slot the fiberglass body tubes. The cutting jig consisted of three boards creating an open-end and open-front box. A photo of the jig is shown below.



Figure 5: Tube Cutting Jig

The top board was attached with a hinge and opened upward. Inside the box, roller wheels were mounted on all three sides, placed in a way to hold the 6-inch body tube inside the box and allow it to spin around its central axis freely. All mounting pieces for the wheels were 3D printed. A spring flange on the top board was used to mount a Dremel, on which an abrasive cutting disk was mounted. The Dremel was mounted so that the cutting disk was perpendicular to the body tube, allowing for the flange to be brought down and the disk to make contact with the surface of the tube. After marking the desired length of the tube, the tube was placed in the jig, and the Dremel was brought downwards towards its surface. The tube was spun slowly on the wheels, cutting it to the desired length.

The slotting jig consisted of a box with two acrylic sides and an acrylic top. The wood boards forming the bottom and two sides were screwed in place. A 6 in diameter hole was laser cut into the two acrylic sides so that the body tube could be inserted into the box. The acrylic top included an additional laser cut slotting pattern, as well as acrylic guides bolted into the top to accommodate a router. A 1/4 in carbide router bit was used to slot the fiberglass tubes. The router was run along the guide, ensuring that the router bit followed the desired placement of the slots for the fins. The jig with the tube in it is shown below.

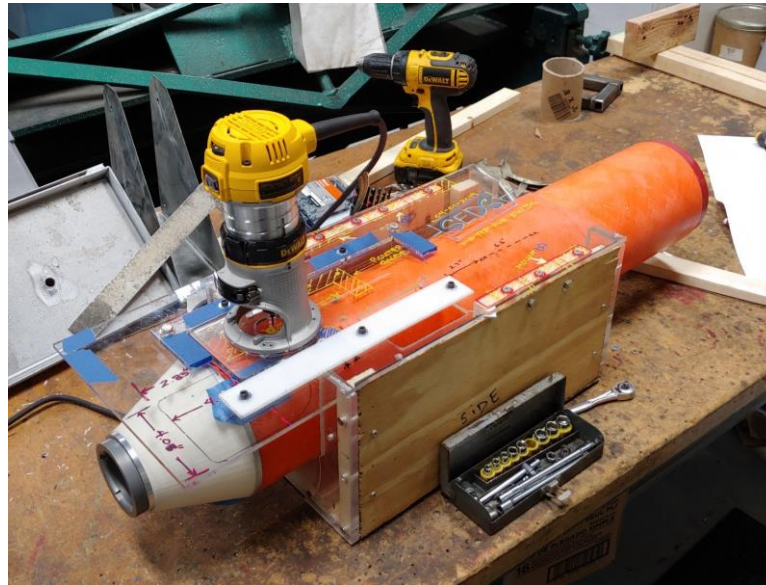

Figure 6: Tube Slotting Jig

2. Fins

From simulations, it was found that a trapezoidal fin shaped produced the most optimal results for our rocket. The general fin specs are shown in Table 3. They are based off the fin diagram in Figure 7.

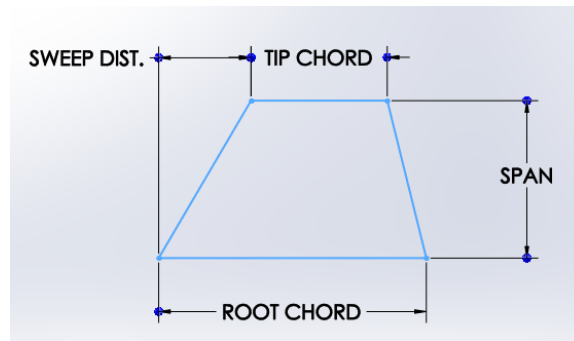

Figure 7: Fin Dimensions Diagram

Table 3: Fin Dimensions

Root Chord (in)	Tip Chord (in)	Span (in)	Sweep Distance (in)
12.1	6.17	7.125	4.1747

To create the fins, they were first modeled in SolidWorks. An airfoil cross-sectional shape was desired which was considered difficult to self-fabricate. To alleviate this, the fins were 3D printed in ABS plastic. To increase the strength of the fins, a composite layup was performed. Figure 8 shows the preliminary 3D printed fin being prepped for layup.



Figure 8: Start of 3D Printed Fin Layup

Because the fins will be slotted, a 3D printed tab was also added with inserts into the rocket. These tabs were lined up with the main body using carbon rods which were inserted through slots created in the print. For the printer of choice, FORTUS 250mc, the lowest infill density was chosen to minimize weight.

Carbon fiber was chosen for the layup largely because the graduate students available to teach us had performed several layups with carbon fiber. First, an outline of the fins was created with carbon fiber. Several “taco-like” shapes were made which allowed us to effectively roll the curved leading edge into it. The tabs were also wrapped to ensure they were also strong. To reduce weight, only two-ply was used. Figure 9 shows the fins laid-up.

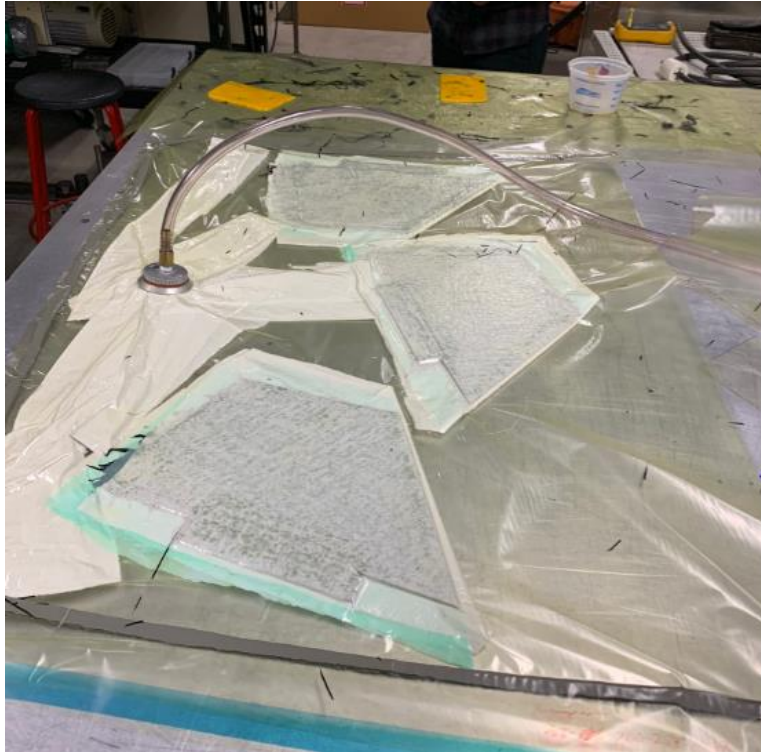

Figure 9: Composite Fin Layup

To increase the strength, Teflon is placed over the composite wrap and finally cotton is placed over that. They are placed in a vacuum bag to suck the epoxy out and minimize weight gain. The Teflon produces a matte finish; thus a clear coat and sanding need to be applied to the final fin to increase smoothness. Excess carbon is trimmed off using composite bandsaws and belt sanders. The finalized product can be viewed in Figure 10.



Figure 10: Finalized Composite Fin

To ensure the fin produced would hold up to the forces found in rocket flight, the fin was simulated in both SolidWorks flow simulation and FinSim. For SolidWorks, the fins were tested at Mach value of 0.7.

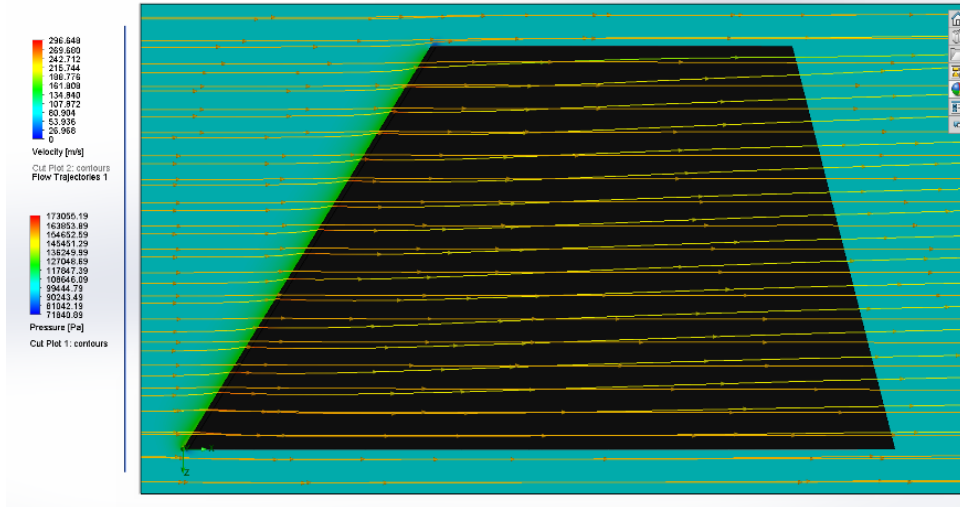

Figure 11: CFD Fin Side View

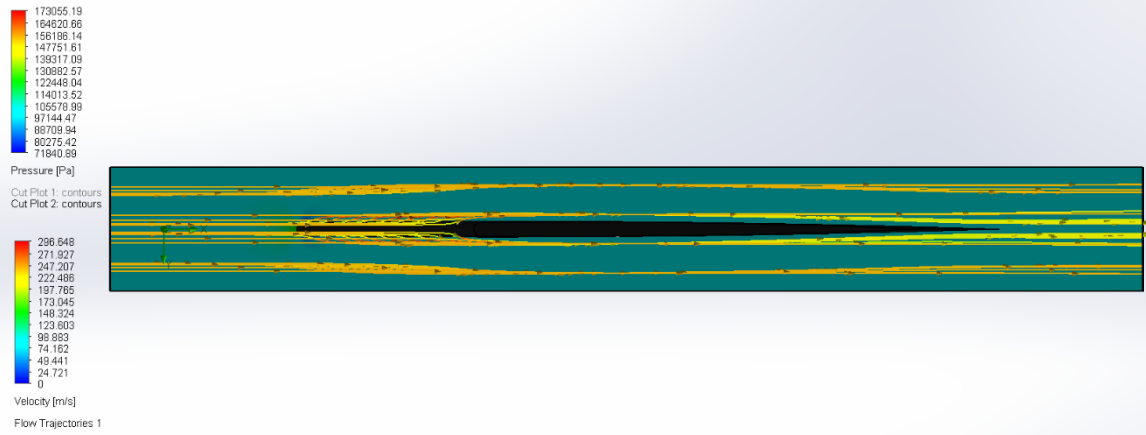

Figure 12: CFD Fin Top View

There are two items being presented on the plots. The lines represent air velocity around the fin and the background is the pressure distribution. There is a pressure build up on the leading edge of the fin which is what was expected. The velocity flow trajectories also show an expected trend. The air flow seems to move smoothly around the fins and transition into a laminar flow state. As the fin begins to taper, the velocity slows and comes together. Furthermore, turbulent flow is not being created, proving the feasibility of our fin design for our Mach value. The pressure data can be exported to SolidWorks simulation to perform FEA. From this, we can determine how the fins will react to the forces. This is shown in Figure 13.

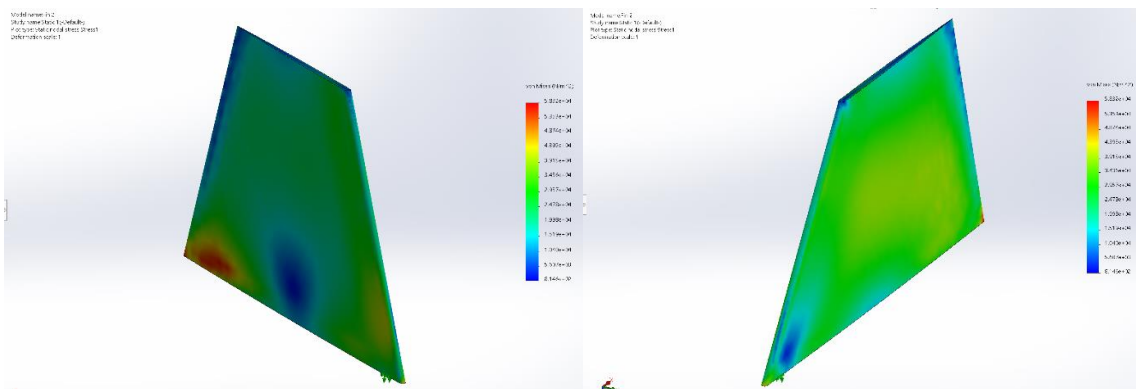

Figure 13: FEA Pressure Analysis

This was simulated with a solid ABS fin. This is not fully representative of the true fin, which has a low-density infill setting to lower weight. However, the fin has a two-ply carbon fiber layup on it to help withstand the forces. From the simulation, we see that the fin is considerably below the yield strength, which isn't listed due to low forces on the fin. Interestingly, the largest stress concentration was on the rear of the fin where it is thinnest. However, there is no indication of the fin fracturing. Furthermore, epoxy could not be modeled on the simulation, thus the true fin will be significantly stronger around the base of the fin attachment where the epoxy fillet is located. Lastly, AeroFinSim was used to check fin flutter.

The AeroFinSim program was utilized to check the maximum allowable velocities of flight at which the fins would not flutter. The program takes an input of the fin geometry, which is based on the dimensions provided in Table 3 above. Although the program allows for the fin material to be specified, it does not allow the definition of a fin geometry with a core of a different material, as was done in the case of the fin construction for this rocket. Thus, as an approximation, the thickness of the fin is under-defined, estimating only the width of the carbon fiber construction. In addition, to be conservative and because of a limited availability of information regarding the weave and type of carbon fiber used, the fin material was set to the carbon fiber available in the program providing the smallest allowable stress.

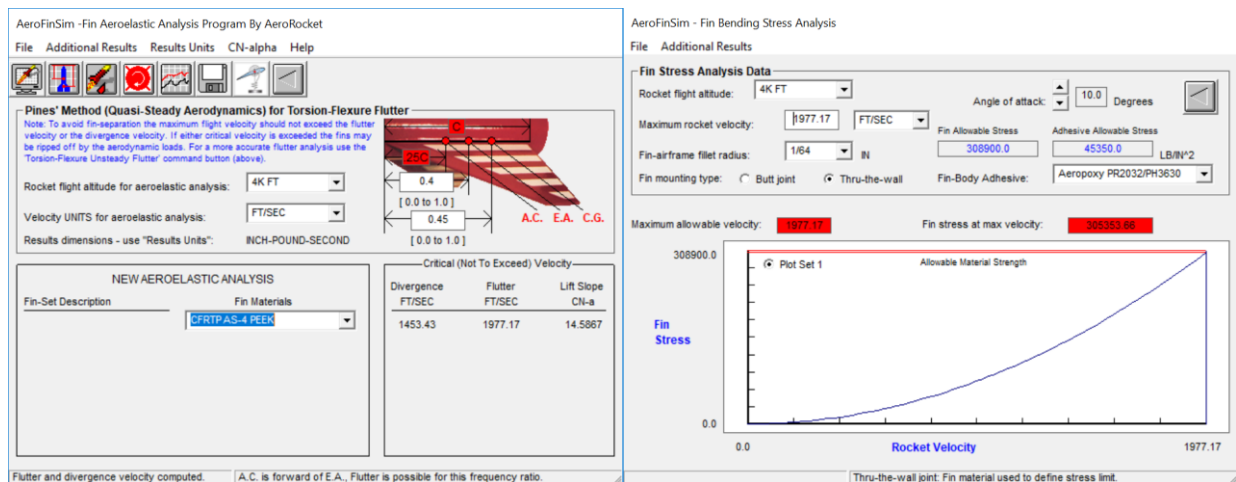

Figure 14: AeroFinSim Maximum Allowable Velocity

Even with these approximations in place, the maximum allowable velocity determined by AeroFinSim was more than twice the maximum flight velocity predicted by RockSim. The maximum flight velocity predicted is 798 ft/s, and the maximum allowable velocity is 1977.17 ft/s. This maximum allowable velocity also remains the same up to a 10 degree angle of attack. Increasing the angle of attack to 15 degrees decreases allowable velocity to 1603.11 ft/s; therefore, even increasing the angle of attack does not yield a maximum allowable velocity near the predicted maximum velocity. Based on these results, the fins are expected to fly without flutter.

3. Boattail and Thrust Plate

A boattail was added to the initial design to assist flow near the bottom of the rocket. Based on early testing, it was found that the addition of the boattail resulted in a height increase of 500 ft. The largest concern of the boattail was it being crushed by the rocket motor when firing. To fix this, a thrust plate and tube were integrated inside the boattail which allowed the motor to sit on the tube. As the motor is fired, the force should travel down the tube to the thrust plate. To ensure feasibility of design, stress analysis was performed in SolidWorks. The results are shown below in Figure 14.

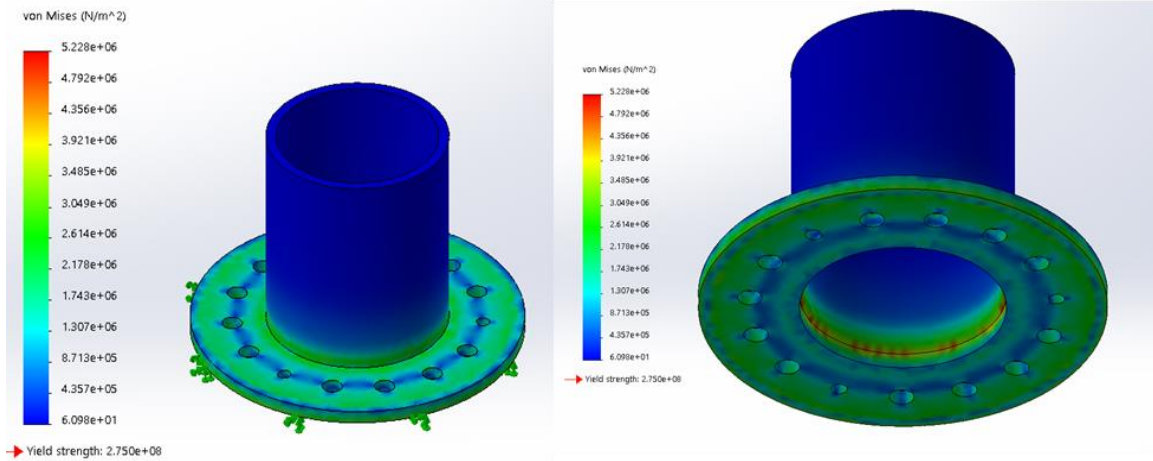

Figure 15: Top and Bottom View Thrust Plate Stress Analysis

For simulation, a load of 400 lbf was placed on the ring at the top of the aluminum tube. This simulates the rocket motor firing while placed on the tube. A ring was drawn around the bottom of the thrust plate which presents the contact area for the tube and thrust plate. This is the location of the supports for the simulation. From the results, the max stress for this loading case is 5.228 MPa, with the yield being 275 MPa. Based on this, we are certain this setup will not yield.

The boattail design primarily stemmed from RockSim simulations. After the optimal design was found, it was modeled in SolidWorks and 3D printed. To determine flow effects, SolidWorks flow simulation was utilized. These results are shown below in Figure 16 and include the bottom portion of the rocket.

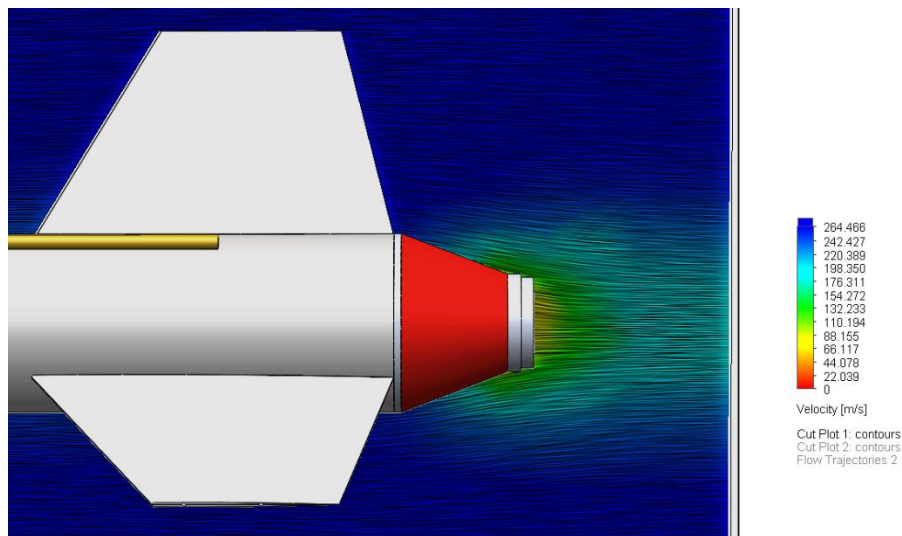

Figure 16: CFD Boattail

The figure displays a cut plot of the velocity as well as the streamlines. Based on this, it appears the boattail is mitigating the formation of eddies in the flow. Based on online research, more uniform, laminar streamlines result in reduced drag, thus a higher altitude can be reached. Furthermore, drag coefficient is a function of the inverse of velocity squared, as indicated by the drag force equation. Therefore, as the velocity drops, so will drag. The flow simulation clearly shows a significant drop in velocity at the boattail; therefore, it is certain drag will go down and cause the rocket to go higher. This is evident from the simulations that the rocket did indeed reach a higher altitude when the boattail was implemented.

C. Recovery Subsystems

The objectives for the team in designing the recovery system was for it to be simple and dependable. It is desirable that the system successfully deploys the drogue and main parachutes for a controlled descent. The avionics being used for the entire recovery phase include two altimeters (main and redundant), and a tracking system utilizing a GPS. The main altimeter and tracking system will also feature a live stream of flight data to an LCD terminal at the recovery team's ground station; which will be further explained below.

1. Parachute Deployment System

The Loveship will utilize a dual deployment parachute recovery system. The separation of the airframe will be done with black powder ejection charges wired to the main altimeter, which will signal the first separation when apogee is reached. The internal pressure required for separation will be obtained using FFFg black powder contained on the bulkheads. The first separation will occur at apogee, where the main parachute and the drogue parachute will both deploy, but only the drogue parachute will inflate. The main parachute will be tied and contained by the Jolly Logic Chute Release mechanism, a COTS component. This mechanism consists of a flight computer programmed to activate a pin release at a pre-programmed altitude. The pin holds a rubber band around the main parachute and prevents inflation of the parachute until the rocket reaches an altitude of 1,500 feet.



Figure 17: Drogue and Main Chute Inflation Testing

The drogue chute selected for the recovery system is a 24" Fruity Chutes elliptical parachute with a spill hole. The drag coefficient is between 1.6 and 1.5 per the manufacturer's specifications; 1.5 is used in calculations to be conservative. The main chute selected for the recovery system is an 84" Fruity Chutes Iris standard parachute with a spill hole. The drag coefficient is 2.2 per the manufacturer specifications. The descent rate of the rocket in both the drogue and main descent phases is calculated by equating the drag force and gravity force acting on the rocket as it falls. A table summarizing the findings is included below. Calculations are based on the rocket's weight after burnout, which is a difference of 5.3 pounds from the 38.5 pound wet weight.

$$f_d = \frac{1}{2} \rho A C_d v^2$$

$$f_g = mg$$

Setting the above two equal to one another, substituting the equation for the area of a circle for A, and solving for velocity yields the following equation. This equation assumes an entirely circular cross-sectional area of the parachute upon descent, where D is its diameter. Resultant calculations using the preceding equation are summarized below. A standard value of 1.229 kg/m³ is assumed for the air density.

$$v = \sqrt{\frac{8mg}{\pi \rho C_d D^2}} \quad (1)$$

Table 4: Parachute Descent Rates

Parachute	Diameter (in)	Cd	Descent Velocity (ft/s)
drogue	24	1.5	82.79
main	84	2.2	19.53

2. Avionics

The *Loveship's* avionics system is consisted of three different circuits. All systems are COTS units which are, Missile Works RRC3 altimeter (Figure 1), Missile Works RTx/GPS Telematics tracking system (Figure 2), and PerfectFlite StratologgerCF altimeter (Figure 1). The RRC3 will serve as the main altimeter and the StratologgerCF will serve as the redundant altimeter. Both altimeters use a barometer to estimate its altitude; and as such, the rocket does require static port pressure holes in order to accurately detect atmospheric pressure. In order to incorporate the StratologgerCF as the redundant altimeter, it is set to ignite the drogue parachute ejection charge at a one-second delay. This will allow the StratologgerCF (redundant) to ignite its ejection charge in case the RRC3 (main) fails for any reason. The one-second delay is a reasonable amount of time to allow for the drogue parachute to deploy, and not so long that the rocket will descend too far in case of failure. These devices are all placed onto an avionics bay that will be held in place inside the tip of the nosecone. The avionics bay features a spot for each device, a battery compartment (Figure 3), and accessible flip switches at the bottom of the bay (Figure 4). The StratoLoggerCF will be powered by a 9V battery, and the RRC3 and RTx/GPS will be powered using a 3.7V LiPo battery (6600 mAh). The 9V battery for the StratoLoggerCF is rated at 500 mAh and should be capable of providing about 20 days of power continuously (quiescent at 1 mA). The RRC3 and RTx/GPS being powered in parallel, has a quiescent current draw of 76 mA combined and a peak current draw (with LED, piezo, and transmitting operation) of 225mA. Since the 3.7V LiPo battery is rated at 6600 mAh, this will allow for about 30 hours of continuous operation (without firing of ejection charges). The ejection charge current draw is at about 5A, so when the RRC3 is being used regularly and for firing the ejection charges, this allows for about 7 hours of operation. The flight and recovery time will take much less time than this, so the selected choices for powering each system was carefully selected and will serve the recovery team well.

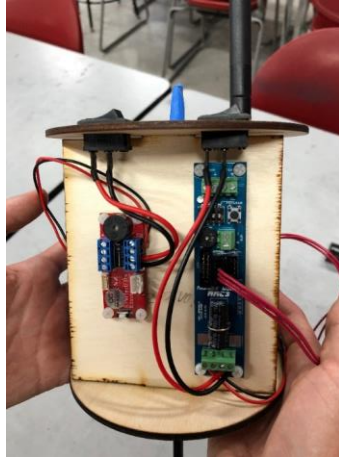

Figure 18: StratoLoggerCF (left) and RRC3 (right) altimeters



Figure 19: RTx/GPS Telematics System

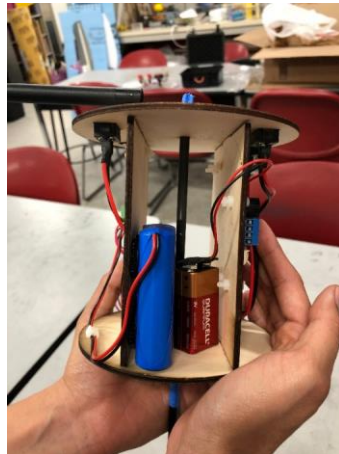

Figure 20: Avionics Bay Battery Compartment

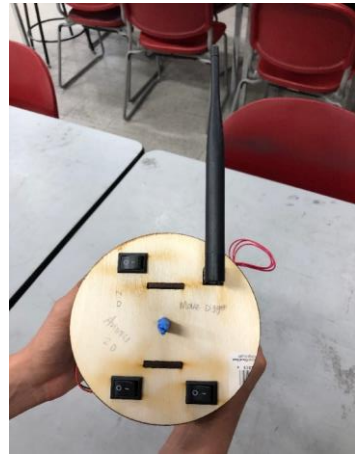

Figure 21: Switches for all devices

The tracking system utilized Missile Works' RTx/GPS tracking system to aid the team in locating the rocket at any given time. This system includes the rocket unit and the base/ground unit. The RTx uses a u-blox GPS module for location tracking. The module connects to satellites used for positioning and will output a National Marine Electronics Association (NMEA) sentence to a ground terminal. If using a computer as the ground terminal, we must use software such as VisualGPS or u-center to read the NMEA sentence and display GPS coordinates in the units desired (decimal degrees). The system works in conjunction with the RRC3 so that the team will also be able to view a live flight data stream also at any given time. The team will be able to observe AGL and MSL altitude, velocity, battery voltage of both the rocket RTx and base RTx as well as their uptimes, GPS coordinates, and GPS fix. In order to view the live flight data, we are using an LCD terminal also supplied by Missile Works. The team has built a ground station that is inside of a protective box. The ground station includes the RTx base/ground unit, LCD terminal, and a switch for operation. The LCD terminal is able to display information such as: latitude and longitude coordinates, MSL altitude and satellite fix, barometric (RRC3) altitude, and battery voltages of both the RRC3 and RTx/GPS base/ground unit.



Figure 22: Recovery Team Ground Station

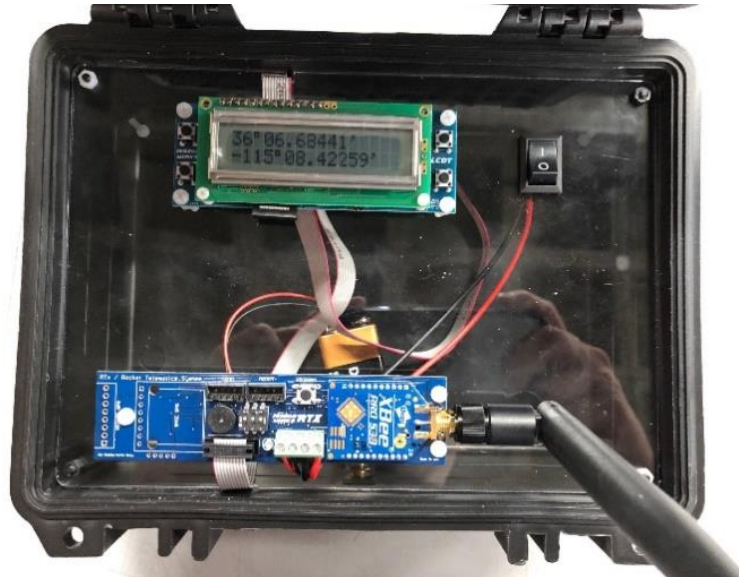

Figure 23: GPS coordinates showing where The Loveship was built

Once the rocket lands, we will be able to view its coordinates on the LCD terminal or computer terminal, and then enter the coordinates into a smartphone to visualize the location on a map. At this point, the team will then be able to walk to the location indicated by the GPS. The RRC3 will be using a piezo buzzer as the audio indicator using a sequence of beeps that indicates apogee reached. At the end of this sequence, there will be a short low tone beep to indicate the altitude reporting as finished, a long pause, and then the sequence will repeat until the altimeter is powered off.

D. Payload Subsystems

The payload subsystem is comprised of three, functional, cube-sat sized payloads. The first of three payloads will be referenced further as “Cube 1”, the second “Cube 2”, and the third “Cube 3”.

The proposed mission of the payload subsystem is to, upon landing on the ground, simulate an expanding habitat module for future plans for the colonization of other planets. The arrangement of the three payloads will be as follows: Cube 3 will sit farthest from the rocket’s nose cone, then on top of Cube 3 will be Cube 1, then Cube 2 will be at the top of the order and will be the closest to the nose cone of the rocket.

Each cube will perform a specific task for the proposed mission. Cube 1 will house the mechanism that will be used to inflate the attached expanding module with compressed CO₂ after touchdown. Cube 2 will house the electronic components that are required for tracking the payload and also determining when Cube 1 is able to deploy the compressed CO₂. Cube 1 and 2 will be mated via an array of nuts and bolts. Cube 3 will not eject from the rocket. Instead, Cube 3 will be used as the mechanism that will deploy/eject the mated Cube 1 and 2. Cube 3 is proposed to use a triggered compressed spring system.

Cube 1 and Component Details:

Cube 1 is comprised of four main components: a flexible bottom base, a central hub, swingable housing doors, and a plastic inflating module. The first component, the flexible bottom base, located at the base of Cube 1, will function as a compressible “bumper” that will absorb the impact when Cube 1 and 2 land on the ground. This bumper is 3D printed from Ninjaflex filament. Ninjaflex filament is an elastic material that can elongate to up to 660% its original length. This allows Cube 1 to utilize a mechanism that will absorb the impact from landing on a hard surface. The flexible bottom covers the bottom surface area of Cube 1 and has a height of 20 mm. Using 3D printing software, the bottom base was designed to have an internal honeycomb structure where the overall volume of the flexible bottom

is comprised of 20% Ninjaflex material and 80% air. The spring coefficient of the flexible bottom was not readily available and was not determined. However, after drop testing, the flexible bottom was confirmed to have prevented the transmission of large impact forces onto the upper components.

The second component of Cube 1 serves as the central hub for the apparatus. This component is seated on top of the flexible bottom of Cube 1, and utilizes a raised crown for proper mating of Cube 1 and Cube 2 via nuts and bolts. ABS filament is used to 3D print the housing apparatus due to ABS being much stronger than the alternative PLA filament. High torque servo motors are mounted to the central hub and provide 21.5 kg/cm of torque. The cables for the servo are routed to the top of Cube 1 where it connects to the electrical components located in Cube 2 via a central opening between Cube 1 and 2. Two 3D printed bevel gears are attached to the servo motors which is also attached to the base of the central hub. The gears are mated at 90 degrees and will actuate the CO₂ inflator valve. The inflator valve is a standard biking valve which serves as an alternative to pumping air into a bike tire via a bike pump. The valve is repurposed to be paired with a threaded 12 g cartridge of CO₂. When the servo motor is mated with the bevel gear, the bevel gears will spin simultaneously and open the CO₂ inflator valve. The released CO₂ gas will then travel through a valve extension tube into the inflatable housing apparatus and begin to inflate until the canister is emptied.

The third component of Cube 1 features four 3D printed doors that enclose the inflatable habitat. The walls connect via a hinge at the base of the cube, which swing outwards from the bottom of the cube. A piano hinge mechanism was created for smooth, simple operation of the walls. Small magnets are embedded to the tops of each of the door and their respective contact points on the cube to allow the cube to remain closed during flight. The magnets allow for the walls to be pushed open when the inflatable habitat has expanded past the volume of the container.

The fourth component is the plastic inflating module that is inflated via the CO₂ mechanism, component 2. The Inflatable habitat is made from thin plastic sheets. 12 g of CO₂ will inflate 2.1 L with a wall pressure of 100 psi. These calculations were used to approximate the require CO₂ to inflate the chosen shape, a torus with an inner diameter of 75 mm. The two plastic sheets that form the habitat were fused together using a laser cutting bed that also produced the shape of the habitat. Power settings for the laser were set to a power and speed appropriate to only melt the sheets together. A cross hatch pattern was selected to fuse the border of the torus.

Cube 2:

The electronics being used in Cube 2 consist of a microcontroller (Figure 1), GPS module (Figure 2), a radio transmitter (Figure 2), and a sensor board. The microcontroller was programmed to receive data from the GPS, and then transmit the data over radio at 433 MHz. The data will be parsed so that it may be easily readable, and it will be received by a radio receiver connected to a computer terminal. This computer will be referred to as the ground terminal, and the GPS coordinates will be displayed in degrees, so that the tracking team will be able to input these coordinates onto a smartphone in order to track the payload.

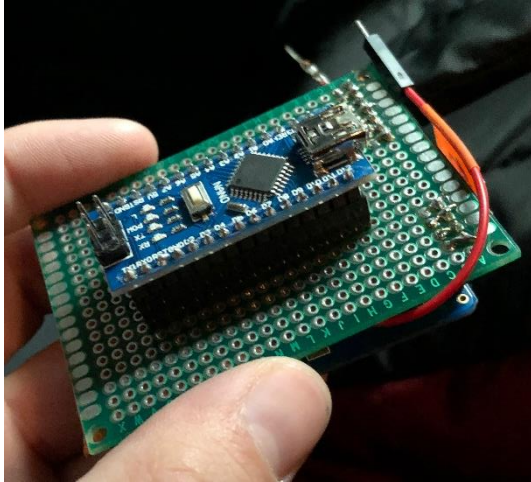

Figure 24: Arduino Nano (Microcontroller)

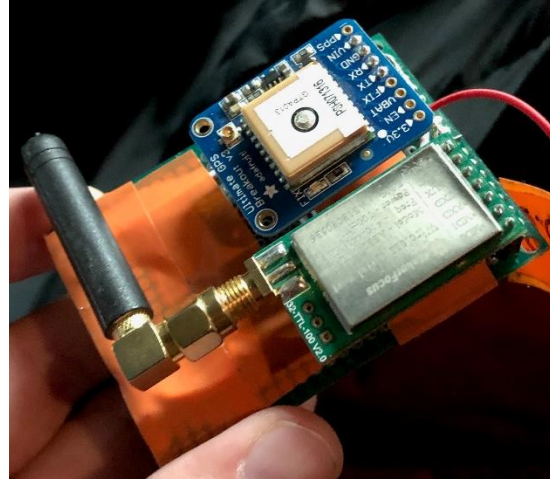

Figure 25: GPS module (upper left) and LoRa radio transmitter (lower right)

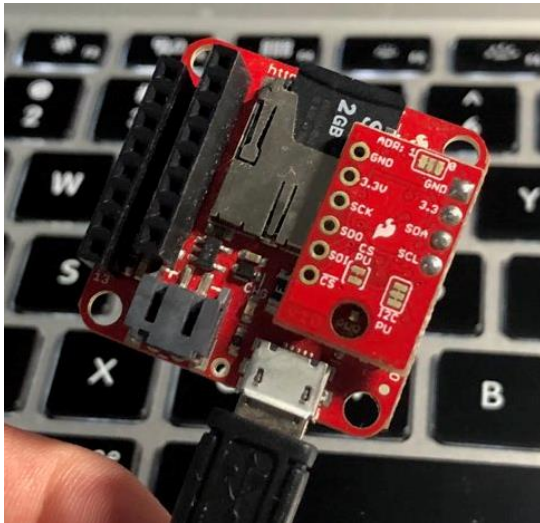

Figure 26: Sensor Board (altimeter, gyroscope, accelerometer, and magnetometer)

```

Time: 0:5:28.0
Date: 5/11/2018
Fix: 1 quality: 1
Location: ██████████
Location (in degrees, works with Google Maps): ██████████
Speed (knots): 0.31
Angle: 188.54
Altitude: 193.10
Satellites: 7
  
```

Figure 27: PC Ground Terminal showing parsed data (censored location due to testing at member's household)

The radio transmitter for this system uses the Semtech's LoRa technology. This technology uses a special kind of modulation, aptly named, LoRa modulation/spread spectrum. This method of modulation can have long-range communication capabilities, while also having low-power consumption. Having researched multiple transceivers with long-range capabilities that have both low-power consumption and are also low-cost, the team decided that this was the best technology to use for the given challenge.

The sensor board contains three separate sensors: altimeter, accelerometer, gyroscope, and magnetometer. The sensor board is programmed separately from the microcontroller and will be used to activate a servo when triggered. This trigger will be when the sensor board has sensed that ground level has been reached. In order to prevent from a false-positive output, the sensor board was programmed so that the altimeter output is not active until the sensor board has traveled more than 10 feet per second.

Once the rocket has launched, it will have reached well over 10 feet per second, and so then the altimeter output becomes active. Since the altimeter is not accurate, the team can ensure higher accuracy of the sensor board sensing it has reached the ground by comparing altitudes over time. This is to say that the code focuses on comparing altitudes so that if, over a span of 10 seconds, the rocket has not moved more than 5 feet (since the altimeter outputs values that are within 5 feet), then the servo will activate. Using a comparator ensures higher

accuracy because no matter what the altitude is, if the rocket has not moved more than 5 feet in 10 seconds, then it must surely be on the ground. The microcontroller circuit, which uses a 5V regulator and 3.3V regulator, will be used to power the servo and sensor board, respectively.

As mentioned before, when the payload has reached the ground, the servo will activate. After the servo activates and turns, it will also turn a gear, which will then open a valve. When the valve opens, the contents of a compressed CO2 canister will release into the inflatable habitat. The sensor board was programmed to turn the servo and close the valve after 5 seconds. This was programmed to the sensor board to prevent the backflow of CO2 gas into the canister.

Cube 3:

III. Mission Concept of Operations Overview

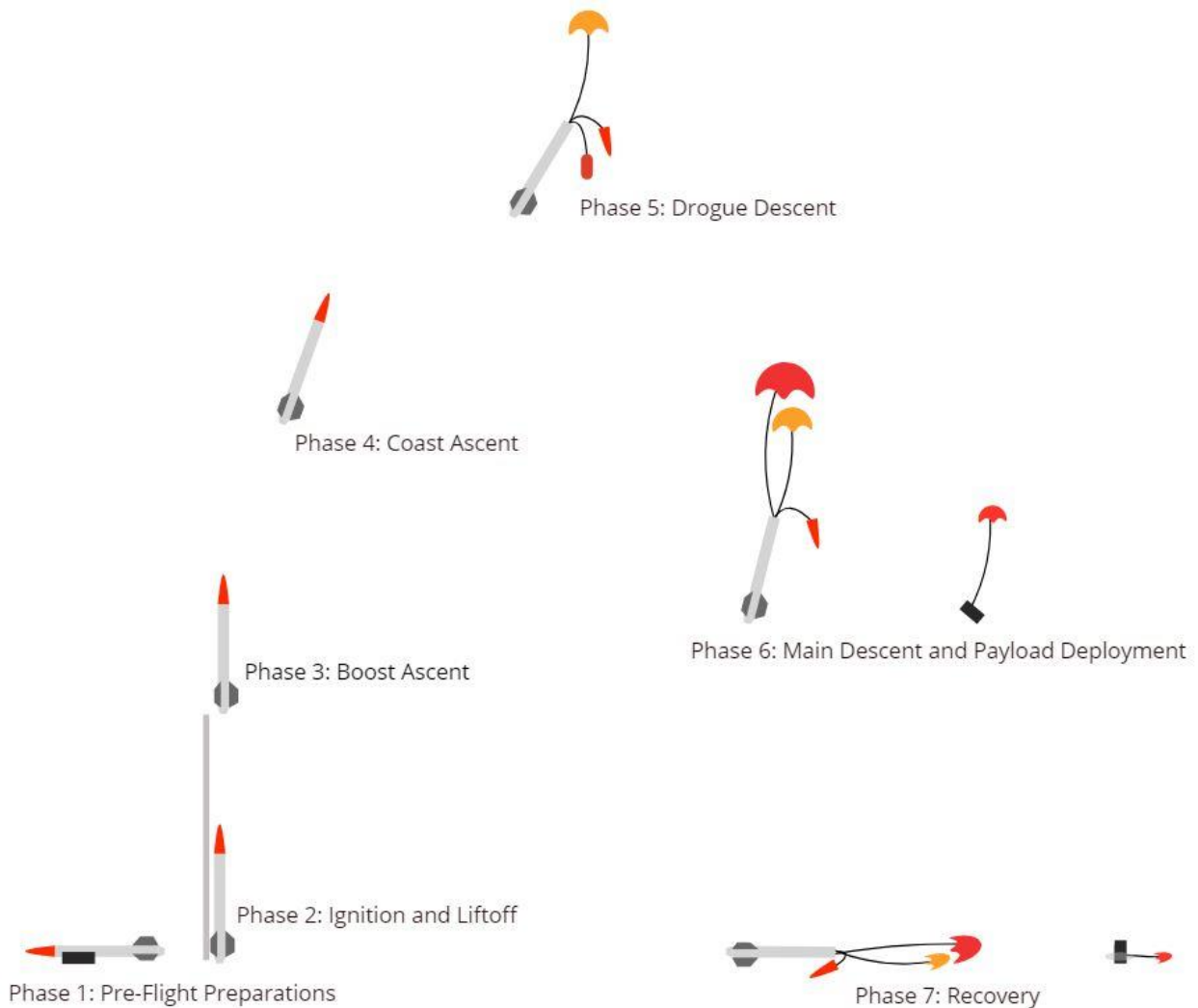

Phase 1: Pre-Flight Operations

The Pre-Flight Operations phase begins as preparations are started to prepare the rocket for launch. Optimal pre-flight operations include the preparation of recovery systems, avionics, and payload. The black powder ejection must be measured out, after which the parachutes for the recovery system must be properly folded into the rocket. The avionics must be turned on and enabled. The payload avionics must be enabled, and the payload must be weighed before integrating into the rocket. Pre-flight operations are essential prior to loading the rocket onto the launch rail.

Phase 2: Ignition and Liftoff

The Ignition and Liftoff phase begins with the signal sent to the igniter in the motor. The rocket is expected travel supported along the 17-foot provided launch rail for approximately 0.5 seconds after the motor ignition.

Phase 3: Boost Ascent

The Boost Ascent phase begins as The Loveship departs from the launch rail. It is expected to leave the launch rail with a speed of 91.0 ft/s.

Phase 4: Coast Ascent

The Coast Ascent phase begins when the motor completes its burn. The Loveship continues to ascend unpowered. At the completion of the motor burn, The Loveship will continue to ascend until it reaches an apogee near 10,000 feet AGL.

Phase 5: Drogue Descent

The Drogue Descent phase begins when The Loveship separates at apogee. The separation at apogee is triggered by the main altimeter. At this separation, both the main and drogue parachute are deployed but only the drogue parachute is inflated. The drogue parachute will slow the rocket to a descent speed of 82.79 ft/s for the duration of the Drogue Descent phase.

Phase 6: Main Descent and Payload Deployment

The Main Descent and Payload Deployment phase begins when the main parachute is released and inflated. The main parachute release via the Jolly Logic chute release occurs at an altitude of 1,500 feet AGL. The main parachute will slow the rocket to a descent speed of 19.53 ft/s. The payload deployment occurs at an altitude of 1,000 feet AGL. The payload's parachute is deployed immediately after ejection.

Phase 7: Recovery

The Recovery phase begins after both The Loveship and its payload have landed on the ground. Upon landing, the payload's sensors will activate and inflate the plastic module. The GPS coordinates are taken from the base telemetry modules for the rocket and payload, and inserted into a smartphone for both. This is utilized to generate a location of the rocket and payload on a map, after which the team will travel to and recover them.

IV. Conclusions and Lessons Learned

The most significant issue faced was weight. In the preliminary simulations, many things were tested for ideal situations, such as weather and surface smoothness. Many parts were also 3D printed and typically reinforced with composite layups and epoxy. Due to the negligence of these items, the rocket came out significantly heavier than initially predicted causing a significant drop in altitude. Based on this, plans to implement overestimation will be used, as most rockets typically weight 1.2-1.4 times the initial estimated values. Fixing this issue will be imperative to the success of future rockets.

Another significant issue faced was lack of hours put in. With such a large gap in communication between different subsystems, some groups fell behind while others got too far and hit stopping points. Setting stricter deadlines and splitting of tasks more evenly will likely help alleviate this problem. In part, this is due to the lack of involved members. The organization is relatively new on campus and we have struggled to get motivated underclassmen involved and participating at the same level as the upperclassmen. This is something we are actively looking to resolve with small workshops and certification rockets.

Besides the issues, we had major success in learning the fundamentals of high-power rocket design. Amongst the group, only one member had participated in anything of this caliber, with a majority of the members never have even launched any rocket before. Great strides were made in telemetry and electronics, payload design and ejection mechanisms, and propulsion simulation and airframe construction. Being that we were new, we decided to try and learn one major item from each rather than taking on everything head on which can be overwhelming. In airframe, members spent time learning how to make composite fins, something that had never been done before at this campus. From this experience, they hope to use those skills to develop tubes and nose cones in the future. For electronics, many members had never used hardware to this degree before. Because of that, they learned integral skills required for systems design. Lastly, payload team discovered the difficulties involved with creating a safe payload that could eject from a rocket without significant damage. With all that was learned, the team truly believes they can come back even better next year, perhaps even in a different, more advanced category.

Appendices

A. System Weights, Measures, and Performance Data



Spaceport America Cup

Intercollegiate Rocket Engineering Competition

Entry Form & Progress Update



Color Key
SRAD – Student Researched and Designed
v19.1

IMPORTANT CHANGE EFFECTIVE IMMEDIATELY FOR SA CUP 2019 EVENT
 All inputs are mandatory for all submissions of this document. We understand some data may change over time, this is completely acceptable.

Feel free to add additional comments where needed, and be sure to fill out the last page. Treat the last page as a "cover letter" for your project.

Date Submitted:

Country:

Team ID: * You will receive your Team ID after you submit your 1st project entry form.

State or Province: State or Province is for US and Canada

Team Information

Rocket/Project Name:

Student Organization Name:

College or University Name:

Preferred Informal Name:

Organization Type:

Project Start Date: *Projects are not limited on how many years they take*

Category:

Member	Name	Email	Phone
Student Lead	Mariana Rodriguez	rodrim11@unlv.nevada.edu	702-332-9996
Alt. Student Lead	Edgar Salas-Sanchez	salase2@unlv.nevada.edu	562-324-3294
Faculty Advisor	Dr. William Culbreth	william.culbreth@unlv.edu	702-895-3426
Alt. Faculty Advisor	Dr. Darrell Pepper	darrell.pepper@unlv.edu	702-895-1056

For Mailing Awards:

Payable To:

Address Line 1:

Address Line 2:

Address Line 3:

Address Line 4:

Address Line 5:

Demographic Data

This is all members working with your project including those not attending the event. This will help ESRA and Spaceport America promote the event and get more sponsorships and grants to help the teams and improve the event.

Number of team members

High School	<input type="text" value="0"/>	Male	<input type="text" value="14"/>
Undergrad	<input type="text" value="16"/>	Female	<input type="text" value="2"/>
Masters	<input type="text" value="0"/>	Veterans	<input type="text" value="1"/>
PhD	<input type="text" value="0"/>	NAR or Tripoli	<input type="text" value="6"/>

Just a reminder the you are not required to have a NAR, Tripoli member on your team. If your country has an equivalent organization to NAR or Tripoli, you can count them in the NAR or Tripoli box. CAR from Canada is an example.

STEM Outreach Events

Our SEDS student chapter participates in an annual event hosted by our college called "Introduce a Kid to Engineering Day." In the past years, we have volunteered to make and launch water bottle rockets with middle school students, introducing them to the basics concepts behind rocketry.

Rocket Information

Overall rocket parameters:

	Measurement	Additional Comments (Optional)
Airframe Length (inches):	73.875	Rocksim provided Cp verified via Barrowman Equation calculations. Shortened length
Airframe Diameter (inches):	6.17	Chosen to accommodate full CubeSat U.
Fin-span (inches):	7.5	Decrease to maintain proper stability along with changes in length and mass.
Vehicle weight (pounds):	28.79	Weight increase as mass estimates of components are updated in early construction
Propellant weight (pounds):	9.706	
Payload weight (pounds):	8.8	
Liftoff weight (pounds):	38.5	Reflects new vehicle weight.
Number of stages:	1	
Strap-on Booster Cluster:	No	
Propulsion Type:	Solid	
Propulsion Manufacturer:	Commercial	
Kinetic Energy Dart:	No	

Propulsion Systems: (Stage: Manufacturer, Motor, Letter Class, Total Impulse)

1st Stage: Casaroni, L1115-P-U, L class, 5015.0 Ns

Total Impulse of all Motors: 5015 (Ns)

Predicted Flight Data and Analysis

The following stats should be calculated using rocket trajectory software or by hand.

Pro Tip: Reference the Barrowman Equations, know what they are, and know how to use them.

	Measurement	Additional Comments (Optional)
Launch Rail:	ESRA Provide Rail	
Rail Length (feet):	17	
Liftoff Thrust-Weight Ratio:	6.47	Thrust = 1093.259 N; Weight = 38 lbs
Launch Rail Departure Velocity (feet/second):	92.53	RockSim Approximation
Minimum Static Margin During Boost:	1.47	Increases to 2 when propellant is out
Maximum Acceleration (G):	18.62	RockSim: Max acceleration = 599.462 ft/s ²
Maximum Velocity (feet/second):	816.11	RockSim Approximation
Target Apogee (feet AGL):	10K	
Predicted Apogee (feet AGL):	9844.9	In the process of optimizing weight

Payload Information

Payload Description:

Mission Plan

Payload will consist of 3 CubeSat units, with each at the standard 10x10x10cm dimensions. The top CubeSat will house an inflatable module and motors, the middle cube houses telemetry and batteries, and the bottom will act as the mechanism that will eject the top and mid CubeSats. Construction of the outer CubeSat frame will be primarily comprised of machined aluminum for robustness or 3D print for weight savings.

Experiment 1: Inflatable Module (FUNCTIONAL)

Our inflatable module in the shape of a torus was inspired by Bigelow Aerospace's BEAM module. Bigelow Aerospace is headquartered in Las Vegas, and we were excited to have something on the ISS developed right in our home! The main objective of this payload is to deploy an inflatable module in the shape of a flattened spheroid/torus that will act as a habitat to humans in an effort to simulate possible missions to occupy Mars or any potentially habitable planet. The payload will have a controlled descent inside the rocket until it reaches an altitude of 1000', at which point the payload will eject from the rocket via the mechanism housed in the lower CubeSat. The payload will be mounted on a rail inside the airframe. Following ejection, the payload will deploy a parachute for a controlled descent to the ground. After landing, the CO2 canister will inflate the habitat material. The GPS has a radio frequency transmitter that will help us to track and recover the payload. The recovery system will utilize the same system as the main rocket body powered by an Arduino, type still to be determined. As safety measures, an arming and disarming system will be added to the deployable unit in conjunction with its deployment to ensure CO2 expansion can be aborted in the event of unforeseen failure to launch.

Cube 3:

The third cube will house the mechanism used to eject the mid and top CubeSat out of the rocket. A spring based system will be used to eject the top cubes.

Payload Materials

- 3D printed ABS Central hub surrounded by inflatable material
- One threaded CO2 cannister and CO2 valve with a servo attachment to the close/open dial
- GPS module with a radio frequency transmitter
- Microcontrollers

Recovery Information

General Implementation of Recovery Systems

Rocket and Payload Recovery

The recovery system is utilized by two independently recovered units: the main launch vehicle and the deployable payload unit. A dual deployment with a main and drogue parachute will be utilized for the main launch vehicle. A singular parachute will be used for the payload unit. Barometric altimeters will control the ejection charges for the parachute deployment. All sensors will be armed prior to launch. The retrieval of the rocket is accomplished using a COTS real-time telemetry system. GPS and altimeter data is sent via RF transmitter (at 900 MHz) to a RF receiver. The coordinates will be used to recover the components at their respective landing coordinates. The data throughout the duration of the flight will be processed using a MATLAB program to generate a 3D plot of the rocket and payload's trajectory.

Overview of Events

- arming sensors on prior to flight
- collecting data through all portions of flight
- rocket reaches apogee
 - drogue chute deploys
 - main chute deploys, is tied and does not expand
 - ejection chargers link to their respective altimeters
- at altitude 1500 ft main parachute will expand after release via Jolly-Logic chute release mechanism
- at altitude 1000 ft, deployable payload unit is ejected, its parachute is deployed
 - the deployed payload unit will have same telemetry setup to record and transmit location
- when received altimeter values equal starting height, GPS data will be used to locate the systems

Recovery Hardware

- COTS real-time telemetry system
- 9V battery (or other)
- Primary Altimeter
- Secondary Altimeter
- GPS Transmitter
- 2 RF Transmitter
- High-gain Antenna

Location of Recovery Systems

- Rocket
 - Nose Cone; Attached via carbon rod and blocked by a bolted in bulkhead
- Payload
 - One cubesat will completely house a recovery system

Detailed Recovery Procedure

Sensors will be armed prior to flight. Body separation for parachute release will be achieved through the use of black powder charges controlled by commercial altimeter units. The drogue parachute deployment system will activate at apogee and utilize a redundancy setup of the altimeter units in order to minimize the possibility of malfunctioning deployment charges. A Missile Works RRC3 (primary unit) and a PerfectFlite StratoLogger (secondary unit) have been chosen to control deployment charges, both units utilizing a barometric sensor to measure altitude. The primary altimeter will deploy a black powder charge at apogee. Should the primary altimeter fail, the secondary altimeter will be programmed with a time delay and ignite a larger black powder charge. From apogee, the drogue parachute (24 inch diameter) will maintain a safe enough descent rate while also countering any major drift which may occur due to cross winds. At 1500 feet, a Jolly-Logic altimeter will release the main parachute (84 inch diameter) which will then reduce the descent rate to a safe range in order to eliminate damage due to ground impact. Throughout flight, telemetry between the rocket and a ground unit will be maintained with the primary focus being GPS data for locating the rocket at landing. Coordinates received from the GPS unit may then be used to obtain the final location of the rocket by inputting them into a map software (Google Maps) which will be correct to within some range. Team members will confirm general direction of landing location using line of sight. Once location is confirmed, team members will spread out and begin walking towards

Planned Tests

* Please keep brief

Date	Type	Description	Status	Comments
10/19/18	Ground	Testing released pressure and volume of	Successful	Resulting volume of approximately 586
10/26/18	Ground	SX1278 LoRa RF module test	Minor Issue	Tested for long range communications.
10/26/18	Ground	CO2 canister expansion and valve test	Successful	Testing volume expansion of canister and
11/2/18	Ground	Adafruit Ultimate GPS module test	Successful	Tested ability to transmit data.
11/7/18	Ground	Testing range of higher gain antennas	Successful	Achieved range of 0.3 mi before
11/9/18	Other	Finalization of Simulation Testing	Successful	Hitting 11K ft in simulation without
12/28/18	Ground	Vacuum Chamber Testing of Altimeters	Successful	Test main and redundant systems in
2/8/19	Ground	Redundant altimeter mode testing	Successful	Testing main and redundant altimeters in
3/16/19	In-Flight	In-flight GPS module test	Successful	Test telemetry range on a mid-power sized rocket.
5/25/19	In-Flight	In-flight sensor testing	TBD	Testing temperature sensor, 3-axis
5/29/19	Ground	Ejection charge pressurization test	TBD	Determine black powder required for
3/22/19	Ground	Payload expansion test	Successful	Testing the full expansion mechanism for
3/22/19	Ground	Payload drop test	Successful	Testing arming of payload after
5/24/19	Ground	Deployed payload failsafe tests	TBD	Test failsafe procedures for a failed
5/22/19	Ground	Idle payload test	TBD	Testing behavior of payload after battery
5/22/19	Ground	Payload inflation mechanism strength test	TBD	Testing pressure inflation materials could
5/24/19	Ground	Payload ejection test	TBD	Testing the ejection mechanism for the

Pertinent Information

Introduction

We are the University of Nevada, Las Vegas's rocketry team under our student chapter of SEDS. In the absence of an aerospace major and department at our university, we founded a rocketry group a year ago in the hopes of getting more hands-on experience with aerospace projects and filling our afternoons with something we're passionate about. Our work as a group has consisted of building rockets from scratch. We made use of materials found in our workshop as well as 3D-printing and laser cutting in an effort to construct as much of the rockets as we could in-house.

This year, we intend to build a rocket to compete in the Spaceport America Cup and become UNLV's first ever competing rocketry team. This rocket would be our largest project to date. Our progress towards competition has been based mostly on the past year's learned experience and independent research through our members.

Project Purpose

While our main objective is to participate in competition, we have also started this project with the intention of establishing something that can be continued by students in the years to come. By extending our outreach and engagement, we are hoping to create interest on our campus for aerospace projects and retain students to develop the experience and skill involved in high-powered rocketry. We believe fully that regardless of the lack of availability of an aerospace curriculum at our university, students have the capability and should have the means to develop the skills to enter the aerospace industry. We are hoping this will be one small step for us, and one giant leap for UNLV.

Progress and Approach

Our research approach to competition calls on us to thoroughly test as many systems and mechanisms as possible to ensure functionality in the overall scope of the project. Thus far, we have been in the finalization of preliminary design of the launch vehicle and payload, as well as initiation of testing individual systems. Defining and purchasing materials has also allowed us to move into the testing and eventually construction phase. We intend to launch full-scale in the next couple of months to allow us time to troubleshoot and manage the first-time entry learning curve.

As for other resources, we have shared our project with numerous faculty with the intent of learning from any related or relevant engineering discipline available to us, even if not directly aerospace related. Such areas include the composites laboratory. We have also reached out to our local Tripoli chapter as a resource. Multiple members are currently working towards obtaining both level 1 and 2 certifications.

Team Composition

Our team is comprised of primarily mechanical engineering students, but also includes electrical engineering, computer engineering, and computer science students. Mechanical engineering students have taken to design, material, and flight analysis through research in construction of the airframe and creating the RockSim simulations, as well as working on the design of the payload unit. Electrical and computer engineering students have taken to developing and testing the required telemetry systems and developing the circuits required for the avionics. Computer science students have taken to data analysis and coding required for the flight systems. However, the systems are interlaced so interdisciplinary cooperation enables us to learn from one another's skill sets.

B. Test Reports

Appendix B will be showing the different tests that were conducted throughout the building of the rocket. This appendix will also show the outcomes of each test.

Subsystem	Description	Outcome	Notes
Recovery Avionics	Vacuum chamber testing of main and redundant altimeters	Successful	Using LEDs as ejection charges, the main altimeter activated drogue and main chutes while the redundant altimeter was delayed by 1 second
Recovery Avionics	GPS data using RTx/GPS	Successful	Using the RTx/GPS, the team was able to successfully receive the correct coordinates over radio
Recovery Avionics	In-flight testing of RTx/GPS	Successful	Launched a mid-power rocket, and used the RTx/GPS for successful recovery – rocket crash landed and RTx/GPS needed repair
Recovery Avionics	GPS and altimeter data with RTx/GPS	Successful	Received GPS and altimeter data on LCD terminal on the ground
Recovery Avionics	In-flight testing of RTx/GPS with RRC3	Pending – launching May 25, 2019	Will be launching a high-power rocket with RTx/GPS and RRC3 on-board to ensure reception of real-time telemetry data
Recovery	Parachute inflation test	Successful	Ensured the parachutes inflated properly when against a wind
Recovery	Ejection charge pressurization test	Pending – May 23, 2019	Determine black powder required for separation charges
Recovery	Proper separation for deployment of drogue chute	Pending – May 23, 2019	Ensure that the nosecone separates from the upper body tube
Payload Avionics	SX1278 LoRa module test	Successful	The module transmits as expected, however, the range was limited to ½ mile
Payload Avionics	GPS data using SX1278	Successful	The module transmits the data as parsed output, however, the range was limited to ½ mile
Payload Avionics	In-flight testing of RFT/GPS	Successful	Launched a mid-power rocket, and used the RFT/GPS for successful recovery – rocket crash landed and electronics were unharmed
Payload Avionics	Drop test of cubes 1 and 2 for proper servo activation	Successful	Early prototype of cubes were used to test the efficiency of code and dropped from a height of 60 feet

Payload Avionics	Drop test of cubes 1 and 2 for proper inflation	Successful	Later prototype of cubes were used to test inflation of habitat and dropped from a height of 60 feet
Payload Avionics	In-flight test of sensor board	Pending – launching May 25, 2019	Will be testing integrity of sensor board under rocket flight conditions
Payload	Payload ejection test	Pending – May 24, 2019	Will be testing for proper ejection of payload with acceleration measurements to ensure proper deployment under real flight conditions
Payload	Deployed payload failsafe tests	Pending – May 24, 2019	Will be testing failsafe procedures for a failed deployment of the payload within the rocket
Payload	Payload inflation mechanism strength test	Pending – May 22, 2019	Testing for the durability of inflation housing, taking into consideration rough surrounding terrain
Payload	Idle payload test	Pending – May 22, 2019	Testing behavior of payload after being inactive while armed for long periods of time to ensure CO2 leaks and battery drain are negligible

C. Hazard Analysis & Risk Assessment

TEAM	PROJECT NAME			
SEDS UNLV	The Loveship			
Hazard	Possible Causes	Risk of Mishap and Rationale	Mitigation Approach	Risk of Failure after Mitigation
<i>Airframe and Propulsion</i>				
Fiberglass or carbon fiber splinters, shavings	Lack of proper safety equipment in cutting, slotting	High; while safety precautions are taken, fibers are small and difficult to control	Proper safety equipment is enforced when using composites, work areas are isolated and cleaned while wearing safety equipment.	Medium

Epoxy skin contact	Lack of proper safety equipment when mixing, using epoxy	Medium; properly cleaning work areas and wearing gloves prevent much contamination, but epoxy is liquid and can run	Areas are properly covered with paper prior to using epoxy. Rubbing alcohol is made available to clean excess on surfaces, gloves worn at all times	Medium
Premature motor ignition	Allowing motor to come near open flame or other heating element	Low; motor is closely monitored during storage and transportation, ignition signal is carefully planned	Motor is stored in cold, dry places for storage and transportation. Setup of the motor into the rocket is done carefully, and preparation for ignition signal is vocalized	Low
	Sending ignition signal prematurely			
Machining tool mishaps	Carelessness or lack of proper training in machining	Medium; Machining tools are never used alone, but still pose risks if misused or if neglected for any period of time	Machining tools are used with supervision. Safety goggles are used, and machines are always turned off and locked when not in use. All members must receive safety training.	Low
	Not securing hair or loose clothing near machining			
<i>Recovery</i>				
Black powder transportation mishap	Sudden impact to transportation container	Low; black powder is contained and closely monitored when in transportation and storage	Black powder is stored in cold, dry places for storage and transportation. Loading of the black powder is done carefully and in a stable, windless area.	Low
	Exposure to open flame or heat source while in container			







Dehydration, heat stroke during recovery	Lack of sun protection and water in high temperatures	High; Competition area is expected to be subjected to high heat and exposure	Sunscreen and water will be readily available for members, hats and other sun gear will be worn.	High
Ejection charge misfire	Avionics prematurely sending ejection charge, causing separation on the ground or prior to apogee	Low; COTS avionics have been tested, and redundancy system is in place	Avionics are tested and all wiring is double-checked to ensure they are in good condition. Redundant system is also tested and timed accordingly.	Low
	Avionics sending no ejection charge			
Wiring failure	Avionics wiring not secured properly during assembly	Medium; wiring is double-checked and ejection tested, but there is enough of it necessary that likelihood still exists	Soldering of wiring is done carefully and thoroughly, ejection charge is tested with avionics loaded into the airframe.	Medium
	Wiring loosened from ejection charge blast			
Power issue	Batteries or avionics run out of charge during flight	Low; Flight does not last very long and components will be prepared ahead of time	A checklist is dedicated to items that must be pre-charged before flight, and fully-charged spares will be kept on hand.	Low
Main chute failure to deploy	Jolly Logic Chute Release malfunction	Low; Chute Release is a COTS component and tested	Chute Release is tested and fully charged prior to competition.	Low
Telemetry failure	Telemetry failure to relay to ground station	Low; Telemetry components are COTS and tested	Telemetry will be tested and placed onto the avionics bay to ensure no damage occurs.	Low
<i>Payload</i>				

CO2 canister mishandling and punctures	Improper storing or handling of the canisters	Low; canisters can handle a fair amount of stress	The canisters will be handled with care and loaded into the payload in the correct order. They will be stored in cold, dry areas prior to use.	Low
	Prematurely threading valve and causing puncture			
Impact during descent	Parachute failure to deploy from payload, resulting in impact to ground	Medium; parachute is intended to deploy immediately after ejection, not being held by anything	Parachute will be folded and contained in a way that allows its easy release after payload ejection.	Low
Failure to deploy	Avionics failure to signal deployment	Low; avionics are tested and COTS components are reliable	The payload avionics will be independently tested, as well as drop tested.	Low
	Spring failure to supply enough force for deployment	Medium; Spring is tested for deployment in a variety of orientations, but flight may remain unpredictable		Medium

D.

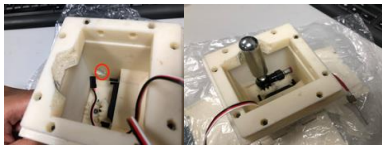



D. Assembly, Preflight, and Launch Checklists

Payload Assembly Checklist		
#	Instructions	Corresponding Figures
1.	Ensure the 3000 mAh powerbank is fully charged by checking the battery level display.	
2.	Unscrew Cube 2 from the top of Cube 1 and remove from apparatus.	 <p>Figure 1: Screw location adhering Cube 2 to Cube 1.</p>

3.	Set the three-way valve to the close position.	 <p>Figure 2: Tightening of valve.</p>
4.	Screw the threaded CO ₂ canister into the valve until the cap of the canister is pierced.	 <p>Figure 3: Canister correctly fastened to valve.</p>
5.	Set the valve to the open position by turning the valve counter clockwise.	
6.	Place valve and cannister into Cube 1 while threading the inflation tube through the inflation hole.	
7.	Connect the 5V and Ground wires from the Payload Telematics device to the servo motor.	 <p>Figure 4: Location of the inflation hole and correct placement of the cannister.</p>
8.	Place the telematics device on top of Cube 1 before covering it with Cube 2.	 <p>Figure 5: Placing of the telematics device before covering with Cube 2.</p>
9.	Screw the base of Cube 1 back onto the housing.	
10.	Pack the deflated inflatable housing inside Cube 1 along with the inflating tube.	
11.	Close each wall of the cube.	 <p>Figure 6: Proper closure of payload housing unit (Cube 1).</p>
12.	Connect powerbank to the USB chord sticking out of Cube 2.	
13.	Ensure parachute is tied tightly around the u-bolt.	 <p>Figure 10: Preferred fastening of parachute to payload.</p>

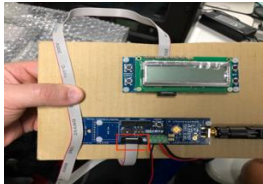
E.

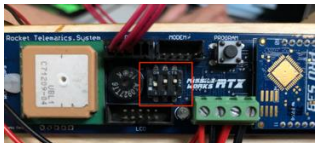
Avionics Bay Preflight and Assembly Checklist

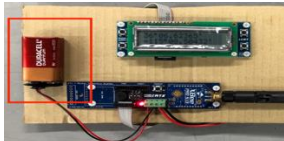
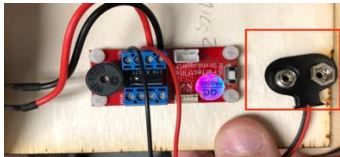
#	Instructions	Corresponding Figures
1.	Connect LCD screen to Base RT _X module.	 <p>Figure 11: Connection of the LCD screen to the base RT_X Module</p>
2.	Connect the communication ports of the Rocket RT _X module to the RRC3 altimeter module.	 <p>Figure 12: Comm port connection on the Rocket RT_X module (left) and the RRC3 Altimeter(right).</p>
3.	Ensure the Li-PO battery is fully charged.	
4.	Test the 9V batteries using volt-meter.	
5.	Ensure the Rocket RT _X module dip pins are set to OFF, ON, ON sequentially.	 <p>Figure 13: Dip switch settings set to OFF, ON, ON for the Base RT_X module</p>
6.	Ensure Base RT _X module dip pins are set to ON, ON, ON sequentially.	 <p>Figure 14: Dip switch settings set to ON, ON, ON for the Base RT_X module.</p>
7.	Connect Li-PO battery to both the Rocket RT _X module and the RRC3 module.	
8.	Connect the 9V battery to the Base RT _X module.	 <p>Figure 15: Connection of the 9V power source to the Base RT_X Module.</p>
9.	Connect a 9V battery to the strato-logger.	 <p>Figure 16: Strato-logger power source connector</p>
10.	Turn on Strato-logger.	
11.	Turn on the Rocket RT _X Module.	

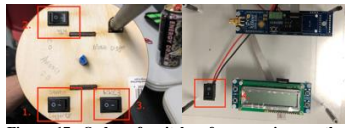
12.	Wait for the “No Sync” buzz tone to signal then turn on the RRC3 altimeter module.	
13.	Wait for the Rocket RT _x module to go silent then turn on the Base RT _x module.	 <p>Figure 17: Order of switches for powering up the avionics system.</p>

Prelaunch Checklist			
1.	Fold the 84 in main parachute.	31.	Apply petroleum jelly to blast disk.
2.	Fold the 24 in drogue parachute.	32.	Remove the nozzle cap and screw in the aft closure til hand tight.
3.	Check the voltage on all 9V batteries.	33.	Check o-rings on nozzle and forward closure. Cracks, general damage.
4.	Perform power test on RRC3 Altimeter. Emits one long beep.	34.	Apply petroleum jelly to o-rings.
5.	Install altimeter sled	35.	Insert forward closure and ejection system into the forward end of the case liner
6.	Install Bulkhead.	36.	Insert reload kit into the aluminum casing. Forward closure first. Rear closure/ nozzle should be flush with the case.
7.	Install upper ejection charge.	37.	Remove the nozzle cap and screw in the aft closure til hand tight.
8.	Continuity test upper ejection charge.	38.	Install motor casing into rocket and screw in the aft motor casing retainer into the rocket.
9.	Connect upper ejection charge to altimeters.	39.	Check CG and mark.
10.	Install lower ejection charge.	40.	RESERVE LAUNCH WITH RSO.
11.	Continuity test the lower ejection charge.	41.	Transport rocket to launch rail.
12.	Connect lower ejection charge to altimeters.	42.	Check condition of launch rail.
13.	Install 1.5 in both upper and lower ejection charges.	43.	Install rocket on launch rail.
14.	Inspect all fasteners on payload assembly.	44.	Check that the angle of the launch rail is no more than 10 degrees.
15.	Tie loop in webbing for parachute attachment located a distance of shrouds plus 6 in from nose cone.	45.	Ensure payload is powered.

16.	Attach webbing to upper bulkhead.	46.	Check telemetry for gps, altitude, and connected satellites.
17.	Slide payload into payload bay.	47.	Power on RRC3 altimeter. Wait for 3 beeps for every 5 s.
18.	Tie loop in webbing for parachute attachment located a distance of shrouds plus 6 in from motor module.	48.	Power on stratologger altimeter. Wait for happy beeps.
19.	Attach webbing to lower bulkhead.	49.	Uncoil the igniter leads in preparation for installation.
20.	Install bulkhead screws with o-rings.	50.	Remove the nozzle cap and install igniter as far as possible (motor length minus 2 inches).
21.	Install 84 in parachute in nosecone.	51.	Bend a loop in leads and reinstall the nozzle cap.
22.	Clip 84 in parachute to loop in webbing.	52.	Ensure igniter wires are inactive.
23.	Install nosecone.	53.	Separate the wires and connect to the ignition circuit.
24.	Install shear pins in nosecone.	54.	Secure wires to rail and place separate from each other.
25.	Install the 24 in parachute into motor module.	55.	Continuity test.
26.	Clip 24 in parachute into loop in webbing.	56.	Move to safe distance.
27.	Install motor module.	57.	Notify RSO of launch readiness.
28.	Install shear pins in motor module.	58.	Wait for RSO approval to launch.
29.	Time delay adjustment: No motor ejection, remove powder from ejection charge.	59.	Launch!
30.	Check integrity of blast disk.	60.	

Charged Items Checklist		
#	Item	
1.	Payload Power Bank	
2.	Telemetry Li-Po battery	
3.	Jolly Logic Chute Release	
4.	9V batteries x 2	
5.		

Checklists without table formatting:

Payload Assembly Checklist:

1. Ensure the 3000 mAh powerbank is fully charged by checking the battery level display.
2. Unscrew Cube 2 from the top of Cube 1 and remove from apparatus.



Figure 3: Screw location adhering Cube 2 to Cube 1.

3. Set the three-way valve to the close position.



Figure 4: Tightening of valve

4. Screw the threaded CO₂ canister into the valve until the cap of the canister is pierced.



Figure 5: Canister correctly fastened to valve

5. Set the valve to the open position by turning the valve counter clock-wise.
6. Place valve and cannister into Cube 1 while threading the inflation tube through the inflation hole.

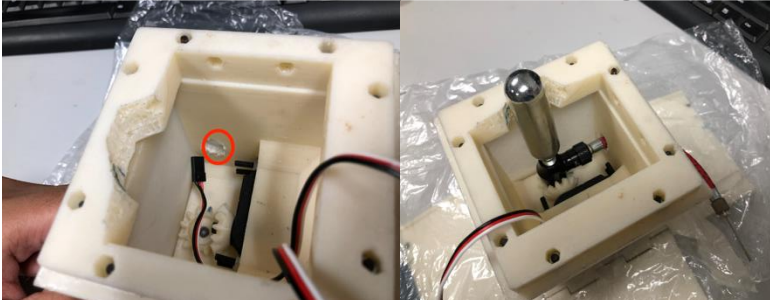

Figure 6: Location of the inflation hole and correct placement of the cannister.

7. Connect the 5V and Ground wires from the Payload Telematics device to the servo motor.

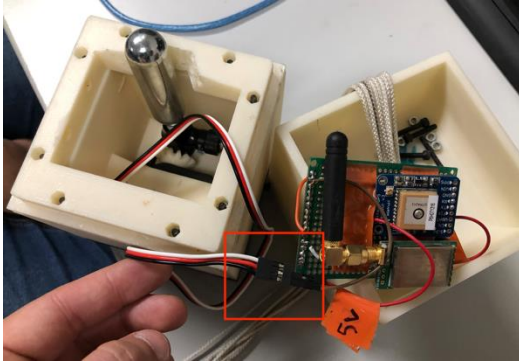

Figure 7: Connection of 5V and Ground wires to the servo motor.

8. Place the telematics device on top of Cube 1 before covering it with Cube 2.



Figure 8: Placing of the telematics device before covering with Cube 2

9. Screw the base of Cube 1 back onto the housing.
10. Pack the deflated inflatable housing inside Cube 1 along with the inflating tube.
11. Close each wall of the cube.



Figure 9: Proper closure of payload housing unit (Cube 1).

12. Connect powerbank to the USB chord sticking out of Cube 2
13. Ensure parachute is tied tightly around the u-bolt

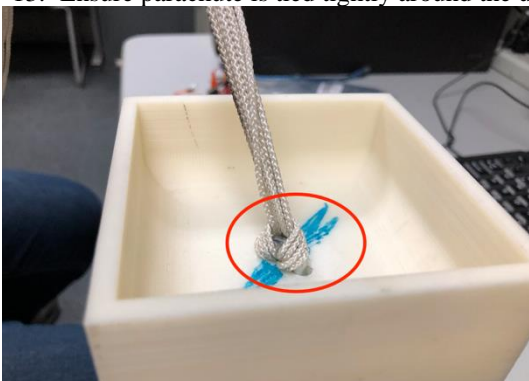

Figure 10: Preferred fastening of parachute to payload.

Avionics Bay Preflight Checklist:

1. Connect LCD screen to Base RT_x module.

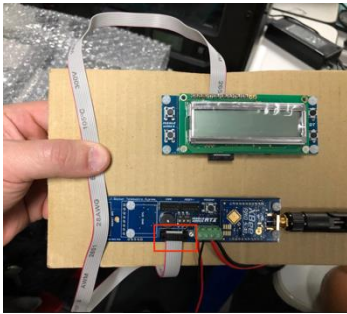

Figure 11: Connection of the LCD screen to the base RT_x Module

2. Connect the communication ports of the Rocket RT_x module to the RRC3 altimeter module.

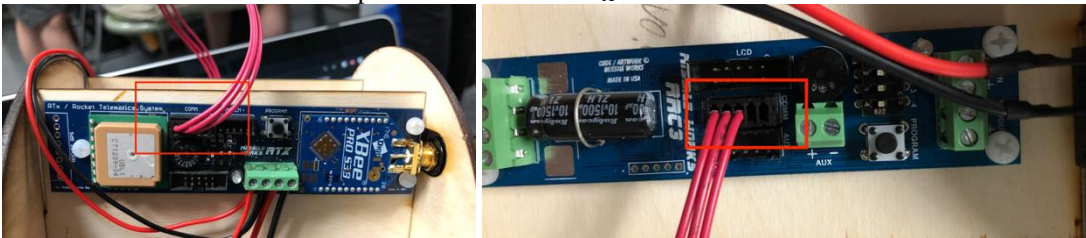

Figure 12: Comm port connection on the Rocket RT_x module (left) and the RRC3 Altimeter(right).

3. Ensure the Li-PO battery is fully charged.
4. Test the 9V batteries using volt-meter.
5. Ensure the Rocket RT_x module dip pins are set to OFF, ON, ON sequentially.

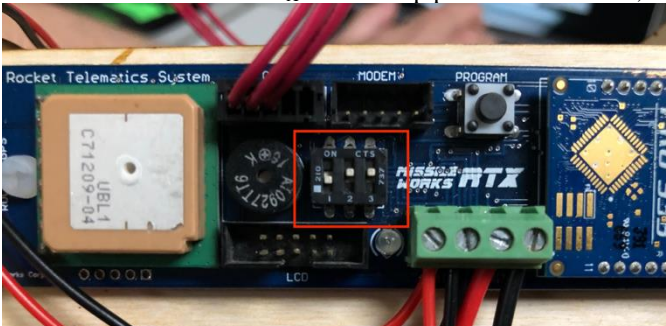

Figure 13: Dip switch settings set to OFF, ON, ON for the Base RT_x module

6. Ensure Base RT_x module dip pins are set to ON, ON, ON sequentially.



Figure 14: Dip switch settings set to ON, ON, ON for the Base RT_x module.

7. Connect Li-PO battery to both the Rocket RT_x module and the RRC3 module.
8. Connect the 9V battery to the Base RT_x module.

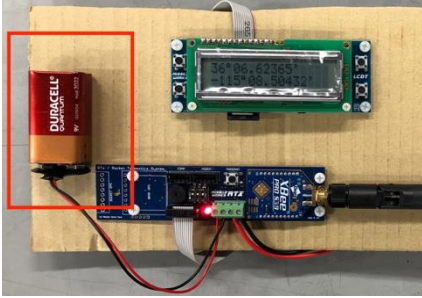

Figure 15: Connection of the 9V power source to the Base RTx Module.

9. Connect a 9V battery to the strato-logger.

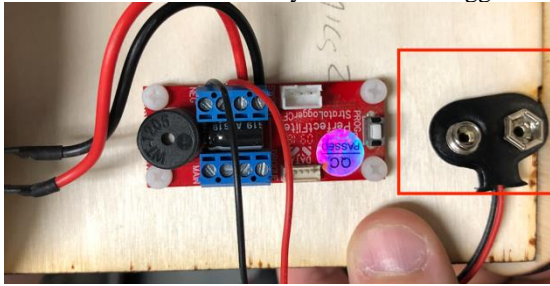

Figure 16: Strato-logger power source connector

10. Turn on Strato-logger.

11. Turn on the Rocket RT_x Module.

12. Wait for the “No Sync” buzz tone to signal then turn on the RRC3 altimeter module.

13. Wait for the Rocket RT_x module to go silent then turn on the Base RT_x module.

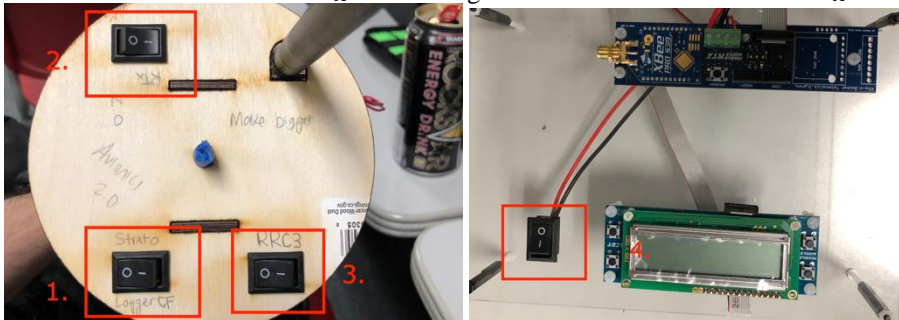
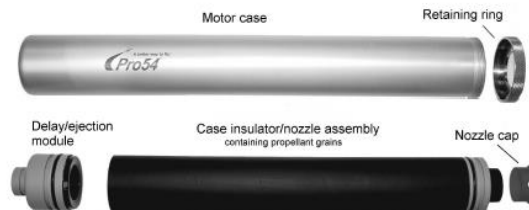

Figure 17: Order of switches for powering up the avionics system.

Preflight Checklist:

1. Fold the 84 in main parachute.
2. Fold the 24 in drogue parachute.
3. Check the voltage on all 9V batteries.
4. Perform power test on RRC3 Altimeter. Emits one long beep.
5. Install altimeter sled
6. Install Bulkhead
7. Install upper ejection charge.
8. Continuity test upper ejection charge.
9. Connect upper ejection charge to altimeters.
10. Install lower ejection charge.
11. Continuity test the lower ejection charge.
12. Connect lower ejection charge to altimeters.
13. Install 1.5 in both upper and lower ejection charges.
14. Inspect all fasteners on payload assembly.
15. Tie loop in webbing for parachute attachment located a distance of shrouds plus 6 in from nose cone.
16. Attach webbing to upper bulkhead.
17. Slide payload into payload bay.
18. Tie loop in webbing for parachute attachment located a distance of shrouds plus 6 in from motor module.
19. Attach webbing to lower bulkhead.
20. Install bulkhead screws with o-rings.
21. Install 84 in parachute in nosecone.
22. Clip 84 in parachute to loop in webbing.
23. Install nosecone.
24. Install shear pins in nosecone
25. Install the 24 in parachute into motor module.
26. Clip 24 in parachute into loop in webbing.
27. Install motor module.
28. Install shear pins in motor module.
29. Time delay adjustment: No motor ejection, remove powder from ejection charge
30. Check integrity of blast disk

Figure 1. Pro54 Components



31. Apply petroleum jelly to blast disk
32. Inspect motor aluminum casing for damage. Dings, bent flanges, out of circularity
33. Check o-rings on nozzle and forward closure. Cracks, general damage.
34. Apply petroleum jelly to o-rings.
35. Insert forward closure and ejection system into the forward end of the case liner
36. Insert reload kit into the aluminum casing. Forward closure first. Rear closure/ nozzle should be flush with the case.
37. Remove the nozzle cap and screw in the aft closure til hand tight.
38. Install motor casing into rocket and screw in the aft motor casing retainer into the rocket.
39. Check CG and mark
40. RESERVE LAUNCH WITH RSO.
41. **Transport rocket to launch rail.**
42. Check condition of launch rail.
43. Install rocket on launch rail.
44. Check that the angle of the launch rail is no more than 10 degrees.
45. Ensure payload is powered.
46. Check telemetry for gps, altitude

47. Power on RRC3 altimeter. Wait for 3 beeps for every 5 s.
48. Power on stratollogger altimeter. Wait for happy beeps.
49. Uncoil the igniter leads in preparation for installation.
50. Remove the nozzle cap and install igniter as far as possible “ motor length minus 2 inches”.

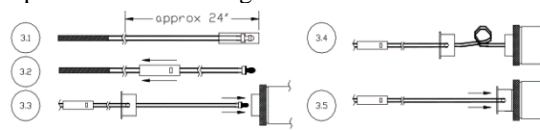

51. Bend a loop in leads and reinstall the nozzle cap.
52. Ensure igniter wires are dead.
53. Separate the wires and connect to the ignition circuit.
54. Secure wires to rail and place separate from each other.
55. Continuity test.
56. Move to safe distance.
57. Notify RSO of launch readiness.
58. Wait for RSO approval to launch.
59. Launch!

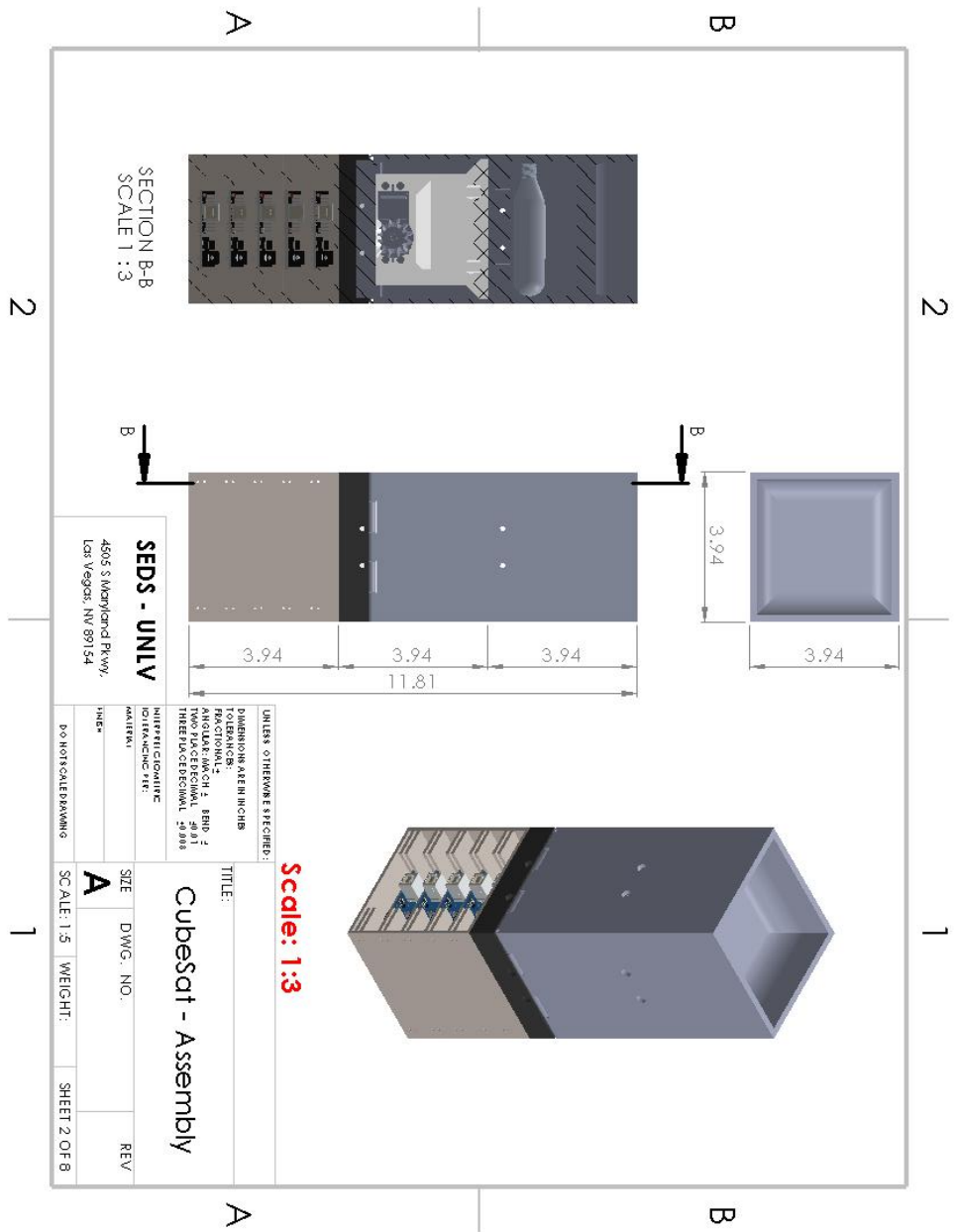

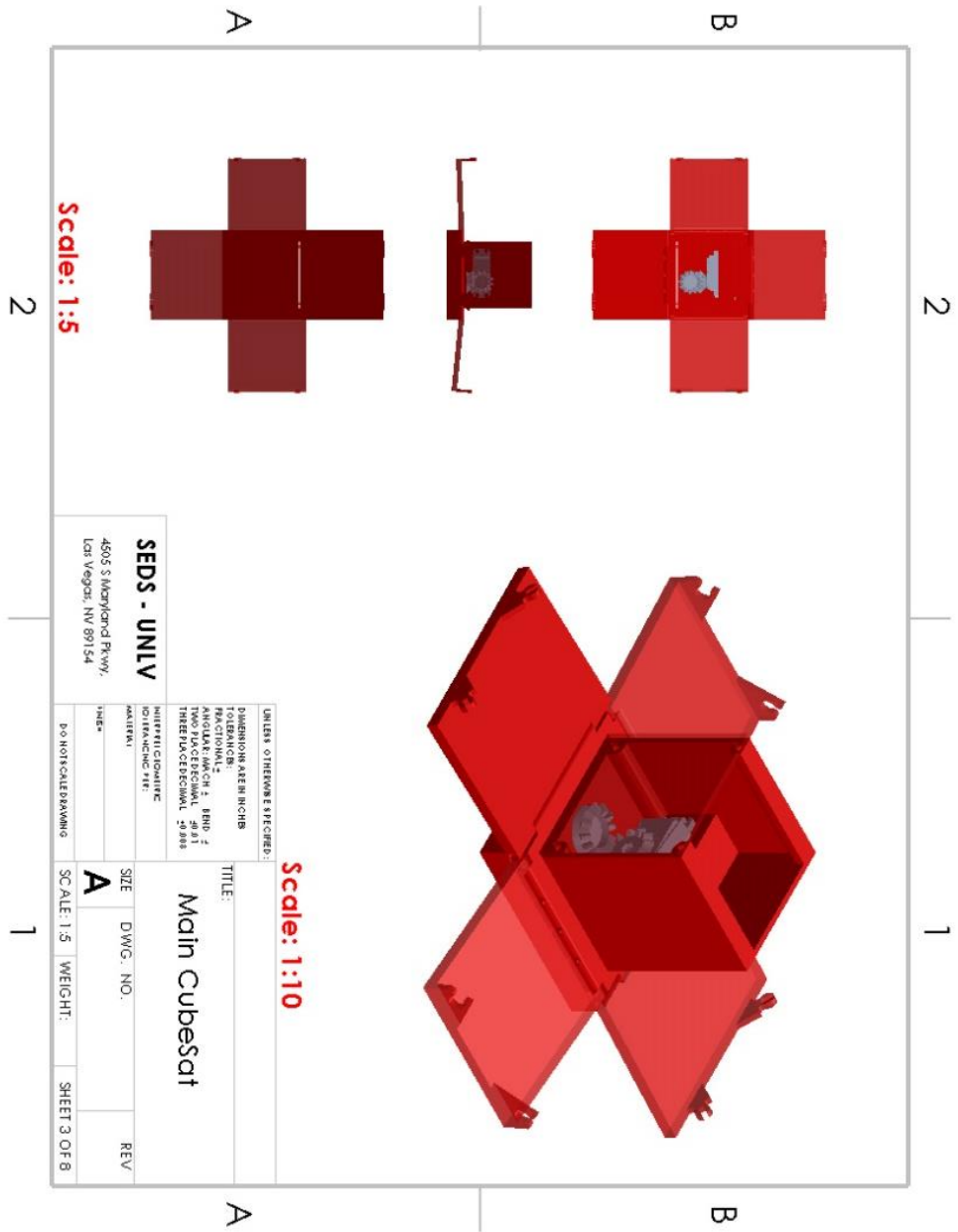

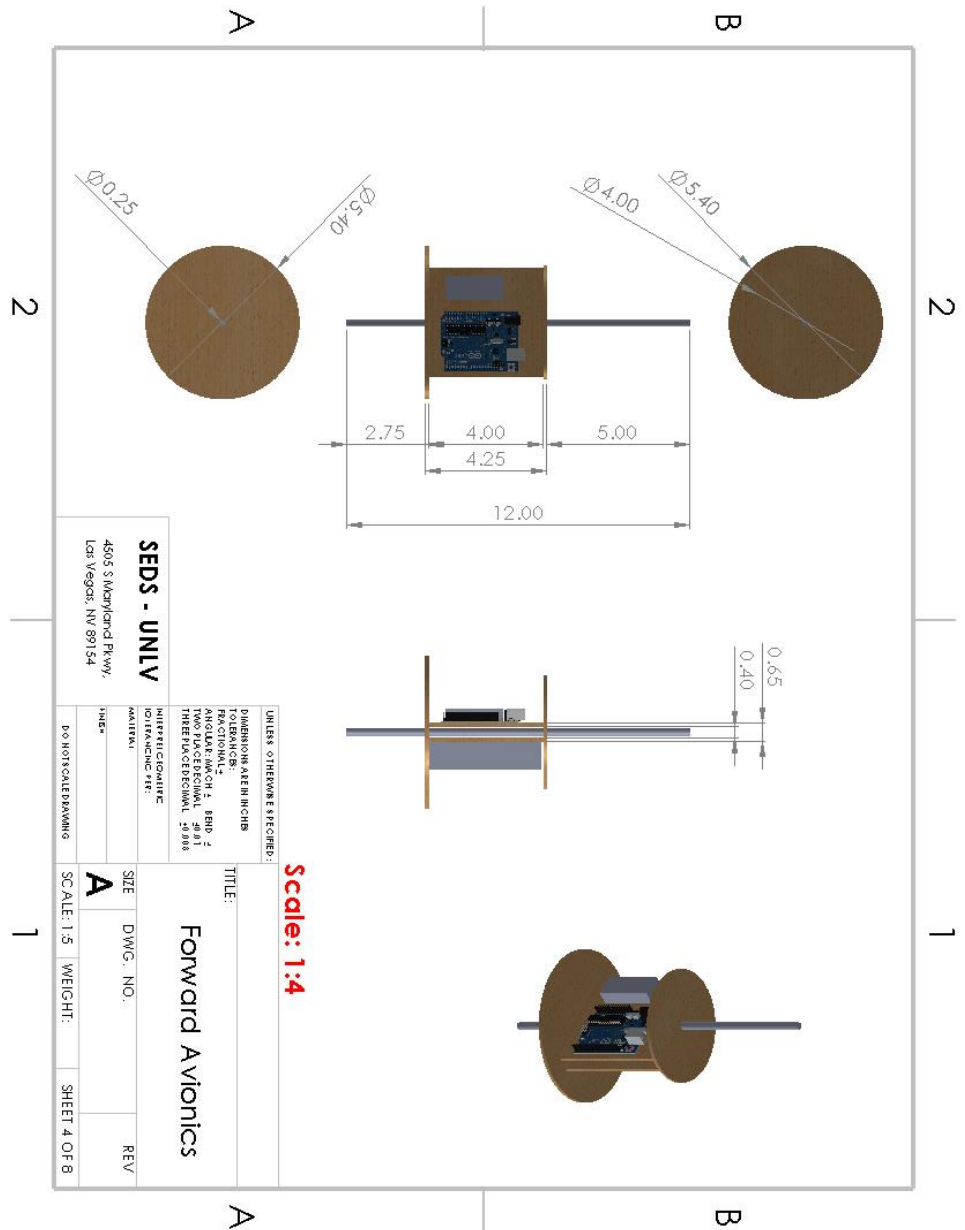

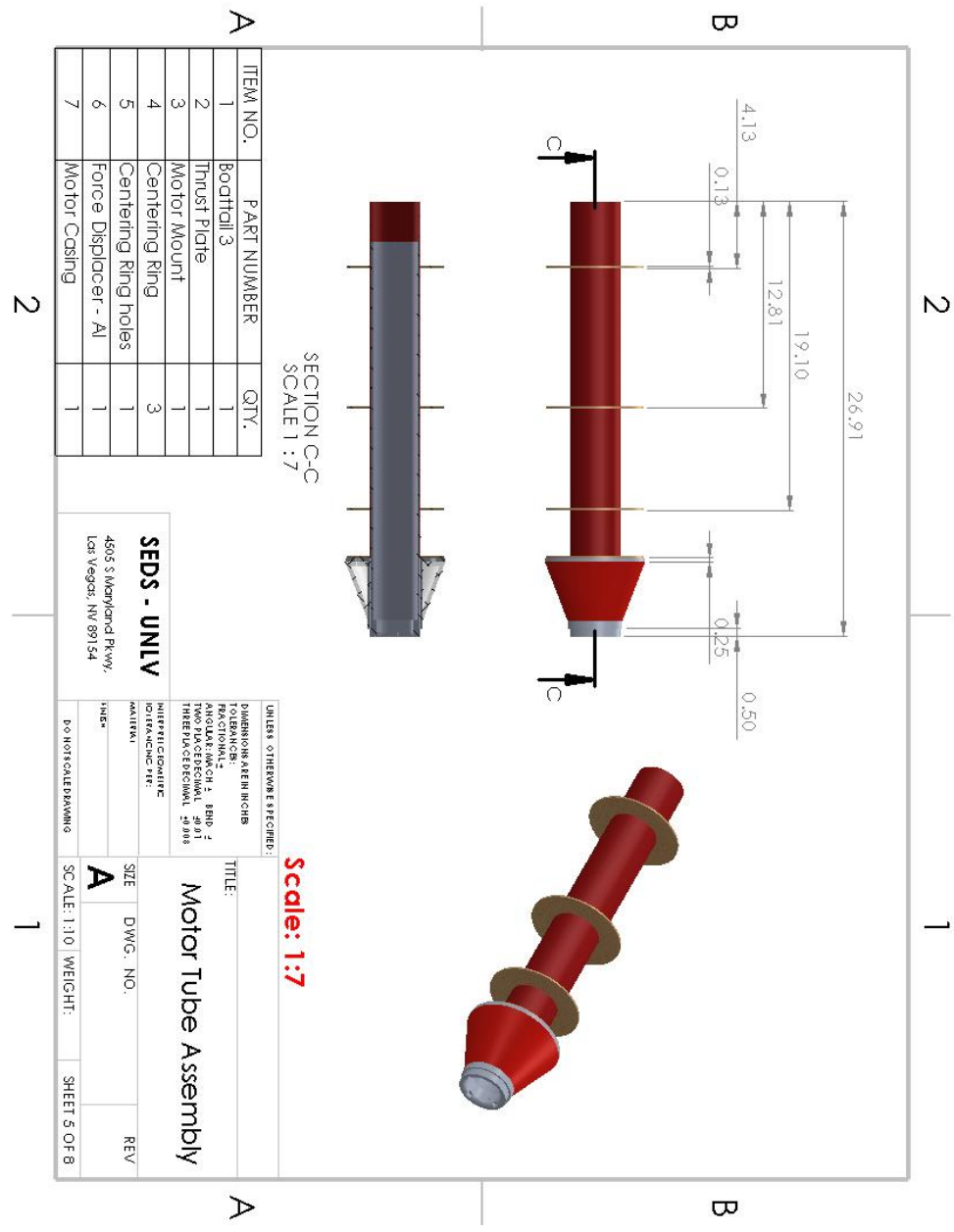

SECTION C-C
SCALE 1 : 7

Scale: 1:7

ITEM NO.	PART NUMBER	QTY.
1	Boothall 3	1
2	Trust Plate	1
3	Motor Mount	1
4	Centering Ring	3
5	Centering Ring holes	1
6	Force Displacer - Al	1
7	Motor Casing	1

UNLESS OTHERWISE SPECIFIED:
 DIMENSIONS ARE IN INCHES
 TOLERANCES
 FRACTIONAL ± .005
 ANGULAR DIMCH ± .010
 HOLE POSITIONAL ± .010
 THREE DECIMAL ± .005
 HOLE POSITIONAL ± .010

SEDS - UNLV
 4505 S Maryland Pkwy,
 Las Vegas, NV 89154

DO NOT SCALE DRAWING

TITLE:
Motor Tube Assembly

SIZE: **A** DWG. NO. REV

SCALE: 1:10 WEIGHT: SHEET 5 OF 8

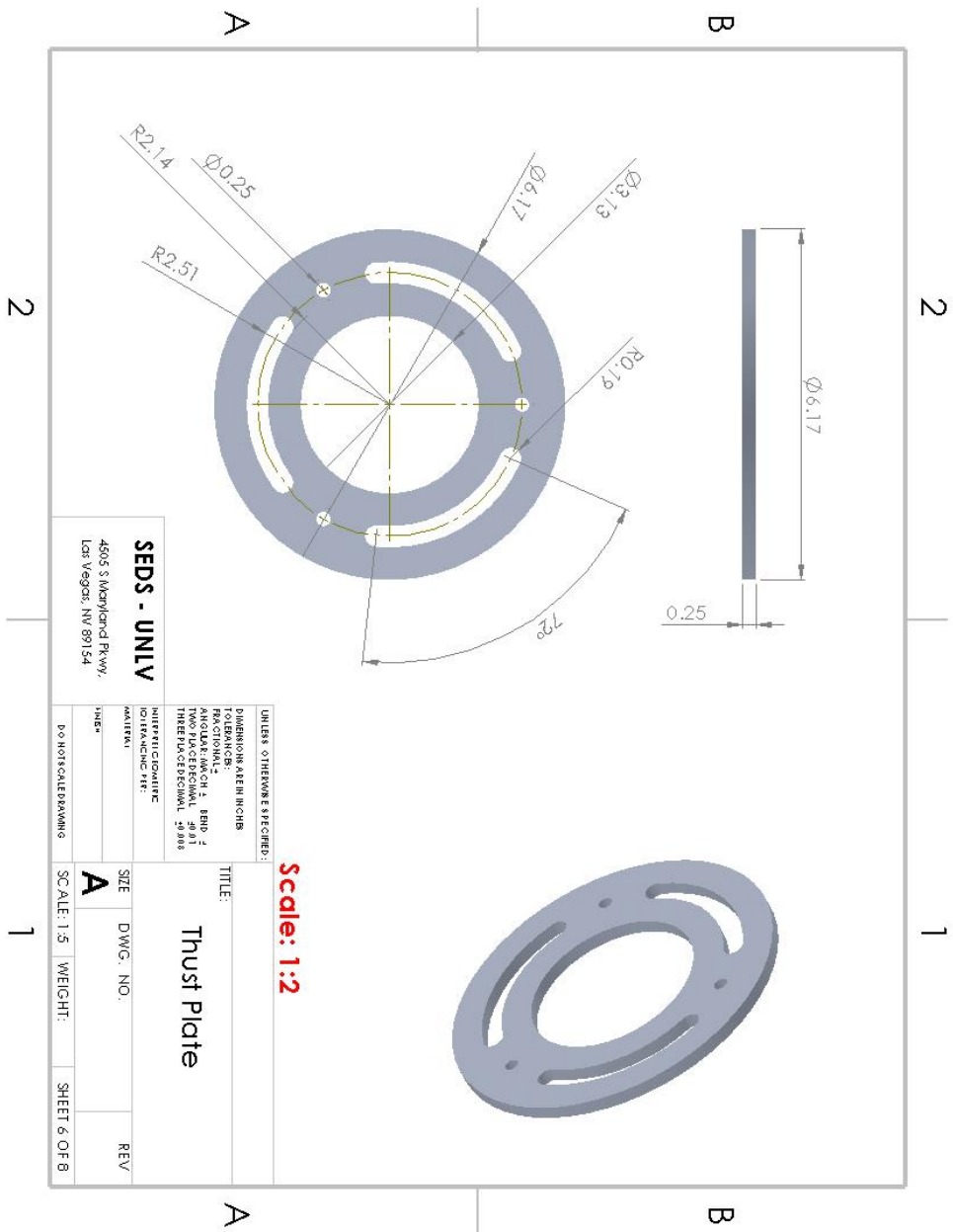

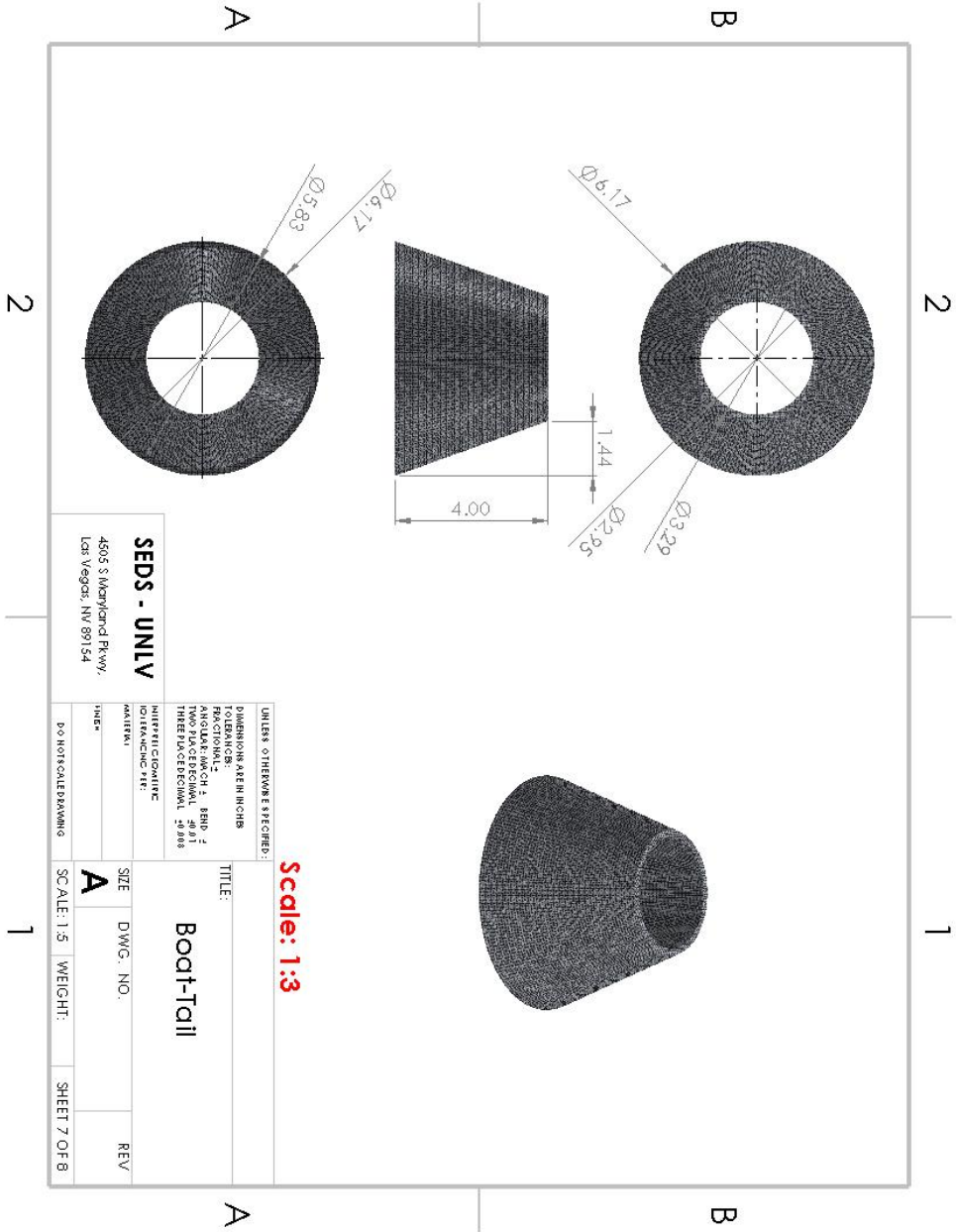

Scale: 1:3

UNLESS OTHERWISE SPECIFIED:		DIMENSIONS ARE IN INCHES	
TOLERANCES		FRACTIONAL	
ANGULAR DIMS: ± .001		± .001	
THREE DECIMALS: ± .001		± .001	
MATERIAL IDENTIFICATION			
MATERIAL		IDENTIFICATION	
TYPE		REV	
DO NOT SCALE DRAWING		SCALE: 1:3 WEIGHT: SHEET 7 OF 8	
SEDS - UNLV		TITLE: Boat-Tail	
4505 S Maryland Pkwy, Las Vegas, NV 89154		SIZE: A DWG. NO.	

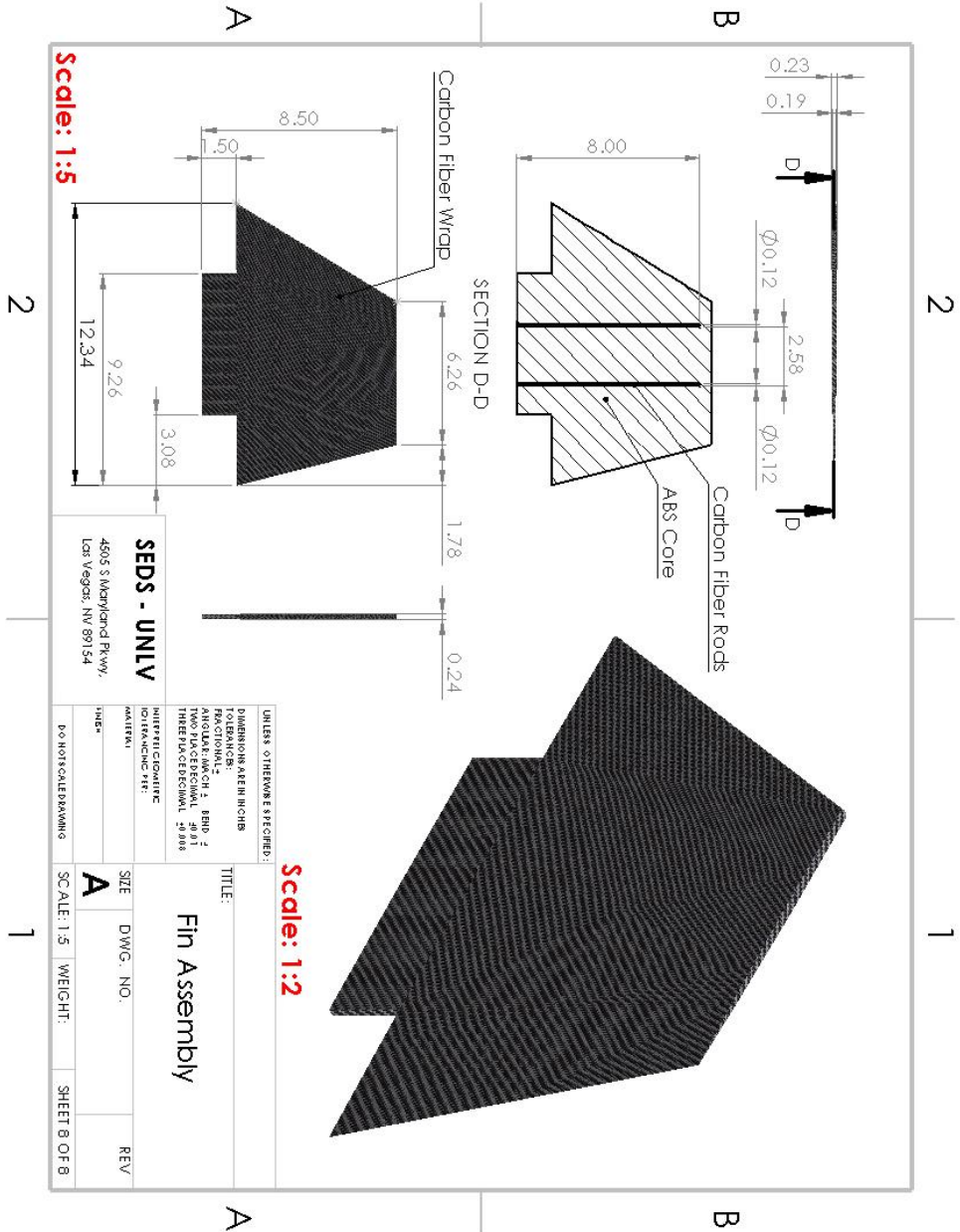

SEDS - UNLV
 4505 S Maryland Pkwy,
 Las Vegas, NV 89154

UNLESS OTHERWISE SPECIFIED:
 DIMENSIONS ARE IN INCHES
 TOLERANCES:
 FRACTIONS ±
 ANGLES ±0.001
 DECIMALS ±0.005
 THREEDIGIT DECIMALS ±0.005

TITLE:		Fin Assembly	
SIZE	DWG. NO.	REV.	
A			
SCALE: 1:5	WEIGHT:	SHEET 8 OF 8	

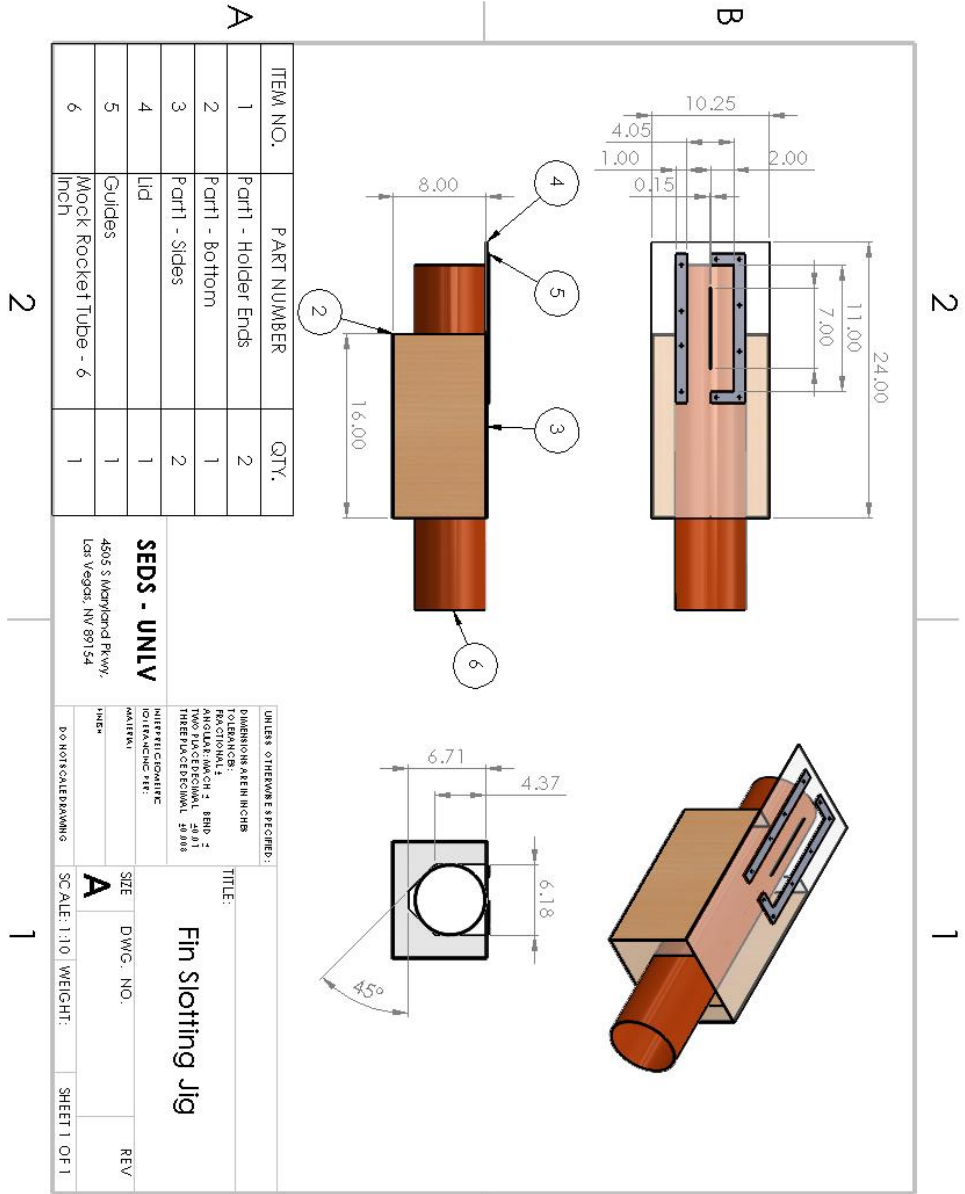

UNLESS OTHERWISE SPECIFIED:
 DIMENSIONS ARE IN INCHES
 TOLERANCES:
 FRACTIONAL ± .005
 ANGULAR ± .001
 THREE PLACE DECIMAL ± .001

SEDs - UNLV
 4505 S Maryland Pkwy,
 Las Vegas, NV 89154

DATE: _____
 DRAWN BY: _____
 CHECKED BY: _____
 APPROVED BY: _____

TITLE: **Fin Slotting Jig**

SIZE: **A** DWG. NO.: _____ REV: _____

SCALE: 1:10 WEIGHT: _____ SHEET 1 OF 1

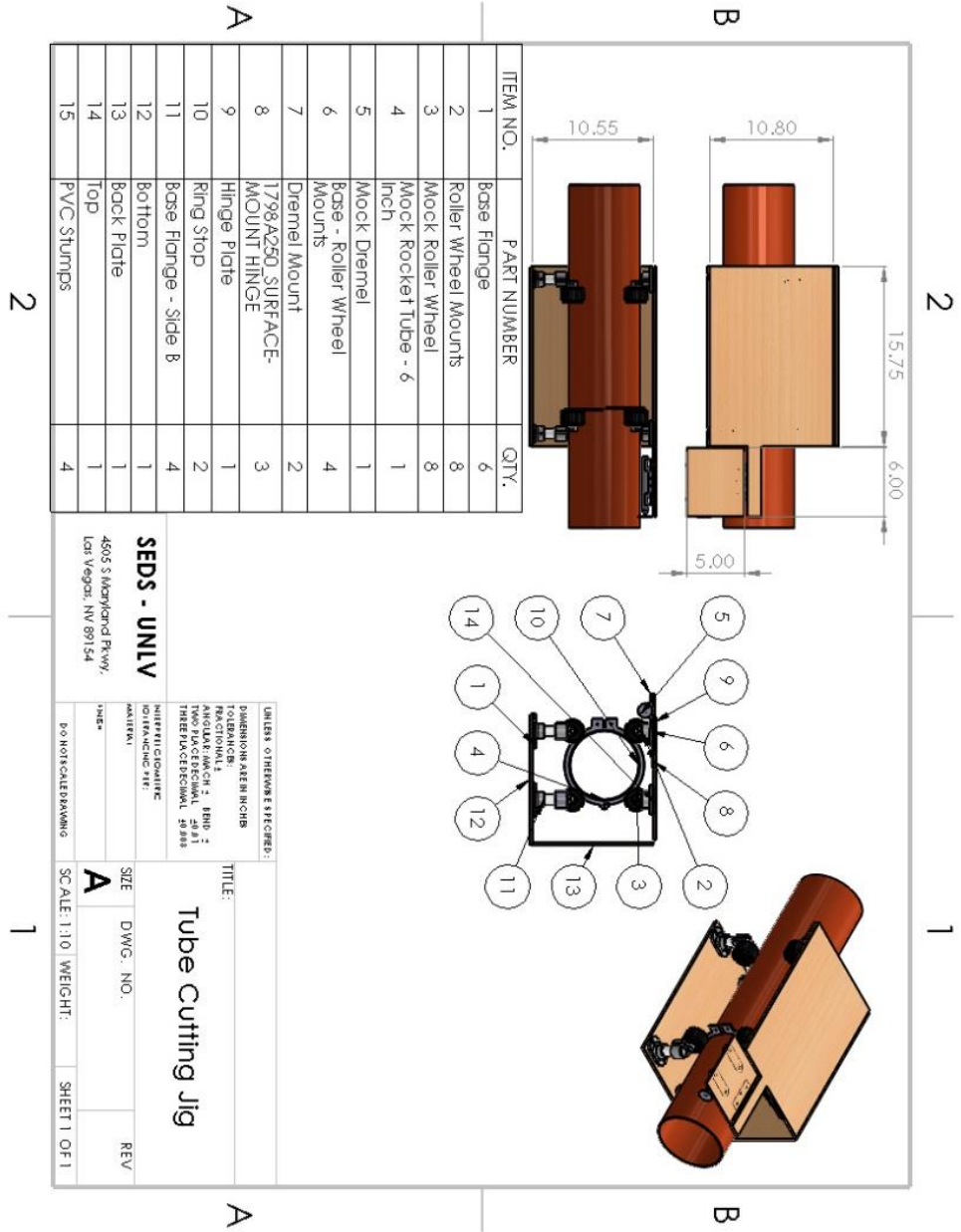

ITEM NO.	PART NUMBER	QTY.
1	Base Flange	6
2	Roller Wheel Mounts	8
3	Mock Roller Wheel	8
4	Mock Rocket Tube - 6 Inch	1
5	Mock Dremel	1
6	Base - Roller Wheel Mounts	4
7	Dremel Mount	2
8	1798A250 SURFACE-MOUNT HINGE	3
9	Hinge Plate	1
10	Ring Stop	2
11	Base Flange - Side B	4
12	Bottom	1
13	Back Plate	1
14	Top	1
15	PVC Stumps	4

SEDS - UNLV
 4505 S Maryland Pkwy,
 Las Vegas, NV 89154

UNLESS OTHERWISE SPECIFIED: DIMENSIONS ARE IN INCHES	
TOLERANCES: FRACTIONAL ± ANGULAR DIMCH ± .000 ± DECIMAL ± .0005 THREE DECIMAL ± .0005	
TITLE: Tube Cutting Jig	
SIZE: A	DWG. NO.:
SCALE: 1:10	WEIGHT:
SHEET 1 OF 1	REV:

References

- Finding Drag Coefficient using Solidworks Flow Simulation. Available at:
[https://www.webpages.uidaho.edu/mindworks/Adv Solidworks/CFD/Drag coefficient of sphere - Final.pdf](https://www.webpages.uidaho.edu/mindworks/Adv_Solidworks/CFD/Drag_coefficient_of_sphere_Final.pdf).
(Accessed: 19th May 2019)
- GoEngineer. SOLIDWORKS Flow Simulation – Stress from Fluid Pressure. YouTube (2011). Available at:
<https://www.youtube.com/watch?v=GQpkG5z7O7A>. (Accessed: 20th May 2019)
- Culp, R. Parachute Descent Calculations. Parachute Descent Calculations Available at:
<http://www.rocketmime.com/rockets/descent.html>. (Accessed: 5th May 2019)
- SemTech. AN1200.22 LoRa™ModulationBasics. Available at:
<https://www.semtech.com/uploads/documents/an1200.22.pdf>. (Accessed: 15th April 2019)